

B.I.S. Symbols used for electrical accessories

Objectives: At the end of this lesson you shall be able to

- interpret the various BIS symbols used in electrical wiring diagrams

In electrotechnical engineering the symbols are used in layouts and wiring circuits to represent the electrical parts or the function of the circuit.











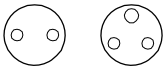
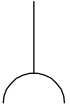







Since the drawing of the actual device is very laborious and would be drawn by each person differently, standardised symbols are used. With the help of the symbols, an electric circuit can be represented easily and can be described precisely as well.

The symbol represents only the function of a part irrespective of the structure and form.

Depending on the purpose of an application, different wiring schemes are used. For example, current flow diagram representation, plans of installation etc. the symbols of various plans of installation (layout) and the current flow diagrams (circuit diagram) differ from one another. A few examples of standard symbols recommended by B.I.S. 2032 (different parts) used for wiring are given here.

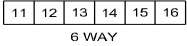
B.I.S. SYMBOLS FOR WIRING SCHEMES







SI.No.	Description	Symbols used in the circuit diagram	Symbols used in layout diagram
1	One-way switch, single pole		
2	One-way switch, two poles		
3	One-way switch, three poles		
4	Multi-position switch single pole		
5	Two-way switch		
6	Intermediate switch		
7	Push-button or bell-push		



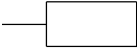
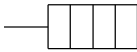



Sl.No.	Description	Symbols used in the circuit diagram	Symbols used in layout
8	Socket outlets, 6A		
9	Socket outlets, 16A		
10	Lamp or outlet for lamp		
11	Fuse		 MAIN & D.B FUSE BOARDS
12	Bell		
13	Buzzer		
14	Earth point		
15	Circuit breaker		
16	Terminal strip		N.A
17	Link (closed)		N.A
18	Plug and socket (male and female)		N.A
19	Ceiling rose		N.A
	N.A: Not applicable		

The B.I.S. Symbols used in the wiring is given here.

ITEMS	SYMBOLS
I Wiring	
1 General wiring	
2 Wiring on the surface	
3 Wiring under the surface	
4 Wiring in conduit	
a Conduit on the surface	
b Conduit concealed	
The type of conduit may be indicated, if necessary.	
5 Wiring going upwards	
6 Wiring going downwards	
7 Wiring passing vertically through a room	
II Fuse-boards	
1 Lighting circuit fuse-boards	
a Main fuse-board without switches	
b Main fuse-board with switches	
c Distribution fuse-board without switches	
d Distribution fuse-board with switches	
2 Power circuit fuse-boards	
a Main fuse-board without switches	
b Main fuse-board with switches	
c Distribution fuse-board without switches	
d Distribution fuse-board with switches	
III Switches and switch outlets	
1 Single pole pull-switch	
2 Pendant switch	
IV Socket outlets	
1 Combined switch and socket outlet, 6A	

ITEMS	SYMBOLS
2 Combined switch and socket outlet, 16A	
3 Interlocking switch and socket outlet, 6A	
4 Interlocking switch and socket outlet 16A	
V Lamps	
1 Group of three 40 W lamps	
2 Lamp, mounted on a wall or light bracket	
3 Lamp, mounted on ceiling	
4 Counterweight lamp fixture	
5 Chain lamp fixture	
6 Pendant lamp fixture	
7 Lamp fixture with built-in switch	
8 Lamp fed from variable voltage supply	
9 Emergency lamp	
10 Panic lamp	
11 Bulk-head lamp	
12 Watertight light fitting	
13 Batten lamp-holder (Mounted on the wall)	
14 Projector	
15 Spotlight	
16 Floodlight	
17 Fluorescent lamp	
18 Group of three 40W fluorescent lamps	

ITEMS	SYMBOLS
VI Electrical appliances	
1 General If necessary, use designation to specify.	
2 Heater	
VII Bells, buzzers and sirens	
1 Siren	
2 Horn or hooter	
3 Indicator (at 'N' insert number of ways)	
VIII Fans	
1 Ceiling fan	
2 Bracket fan	

ITEMS	SYMBOLS
3 Exhaust fan	
4 Fan regulator	
IX Telecommunication apparatus	
1 Aerial	
2 Loudspeaker	
3 Radio receiving set	
4 Television receiving set	

Electrical wiring accessories

Objectives: At the end of this lesson you shall be able to

- classify, specify, identify and state the uses of the accessories employed in domestic wiring
- state the IE rules related to safety and electric supply.

Electrical accessories: An electrical domestic accessory is a basic part used in wiring either for protection and adjustment or for the control of the electrical circuits or for a combination of these functions.

Rating of accessories: The standard current ratings of the accessories are 6, 16 and 32 amps. The voltage rating is 240V AC as per B.I.S. 1293-1988.

Mounting of accessories: The accessories are designed to mount either on the surface or concealed (flush type).

Surface mounting type: Accessories are provided with a seating so that when mounted they project wholly above the surface on which they are mounted.

Flush-mounting type: These accessories are designed to mount behind or incorporated with a switch plate, the back of the plate being flush with the surface of the wall or switch box.

The electrical accessories used in wiring installation, are classified according to their uses.

- Controlling accessories
- Holding accessories
- Safety accessories

- Outlet accessories
- General accessories

Controlling accessories: The accessories which are used to control the circuits or an electrical point like switches are called 'controlling accessories'. All the switches are specified in accordance with their function, place of use, type of mounting, current capacity and working voltage. For example - S.P.T. (Single pole tumbler) flush-mounted switch 6 amps 240 volts.

Types of switches according to their function and place of use

- 1 Single pole, one-way switch
- 2 Single pole, two-way switch
- 3 Intermediate switch
- 4 Bell-push or push-button switch
- 5 Pull or ceiling switch
- 6 Double pole switch (DP switches)
- 7 Iron clad double pole, (ICDP) switch.
- 8 Iron clad triple - pole (ICTP) switch.

Of the above 1,2,3,4 and 6 may be either surface mounting type or flush-mounting type.

Single pole, one-way switch: This is a two terminal device, capable of making and breaking a single circuit only. A knob is provided to make or break the circuit (Fig 1). It is used for controlling light or fan or 6 amps socket.

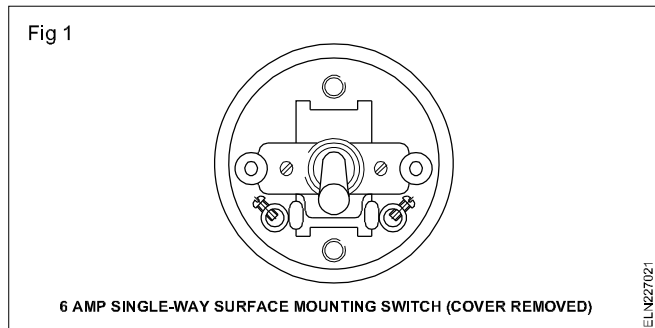

Single pole, two-way switch: This is a three terminal device capable of making or breaking two connections from a single position (Fig 2). These switches are used in staircase lighting where one lamp is controlled from two different places. Though four terminals could be seen, two are short circuited and only three terminals are available for connection.

However, both single way and two-way switches with their cover look alike (Fig 2b) but can be differentiated by looking at the bottom. Single way switches will have two terminal posts whereas two-way switches will have four terminal posts.

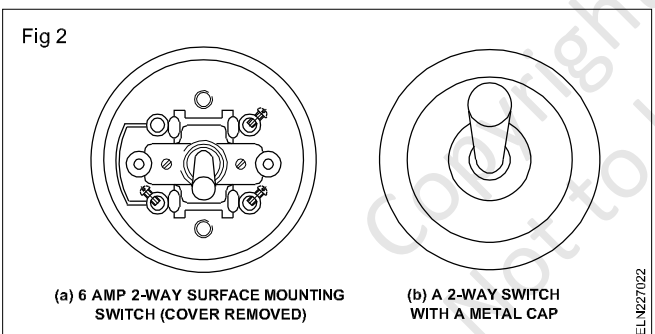

Intermediate switch: This is a four-terminal device capable of making or breaking two connections from two positions (Fig 3). This switch is used along with 2 way switches to control a lamp from three or more positions.

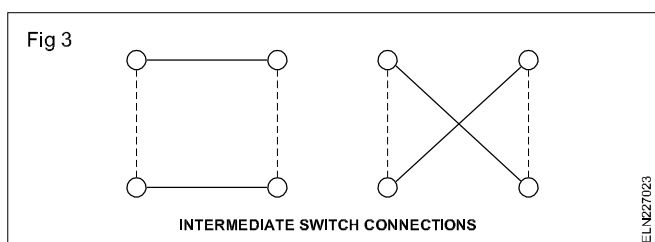

Bell-push or push-button switch: This is a two-terminal device having a spring-loaded button. When pushed it 'makes' the circuit temporarily and attains 'break' position when released.

Pull or ceiling switch (Pendent switch): This switch is normally a two-terminal device functioning as a one-way switch to make or break a circuit (Fig 4).

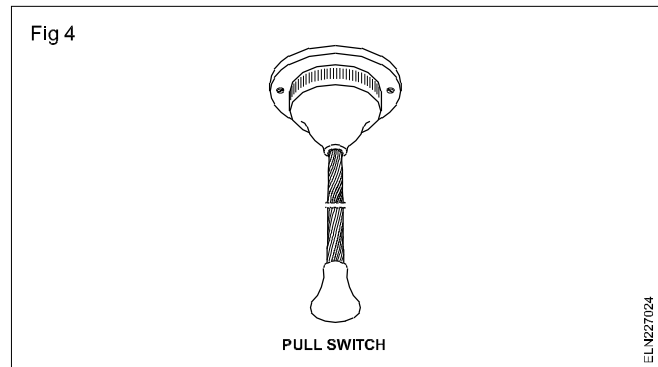

This switch is mounted on ceilings. As the user could operate the switch from a distance through the insulated cord, this could be used safely for operating water heaters in bathrooms or fan or lights in bedrooms.

Double pole switch (DP switch): This is a switch with two poles, the two poles being mechanically coupled together. It is operated with a knob. It is also provided with a fuse and a neutral link. These switches are used as main switches to control main or branch circuits in domestic installation.

Iron - Clad Double pole (ICDP) main switch : This switch is also referred to as DPIC switch and is mainly used for single phase domestic installations, to control the main supply. It controls phase and neutral of the supply simultaneously (Fig 5).

This switch consists of two fuse-carriers. The one in the phase circuit is wired with the fuse and the other in neutral is linked with a brass plate or thick copper wire. These switches should be earthed properly to safeguard the user. The current rating of the switch varies from 16 amps to 200 amperes.

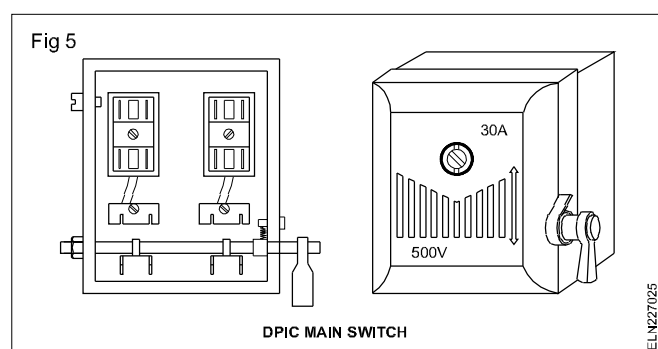

Specification of these switches should have:

- current rating
- voltage rating
- type of enclosure (sheet steel or cast iron).

Iron - Clad Triple pole (ICTP) main switch: This is also referred to as TPIC switch and is used in large domestic installation and also in 3-phase power circuits, the switch consists of 3 fuse carriers, one for each phase. Neutral connection is also possible as some switches are provided with a neutral link inside the casing (Fig 6).

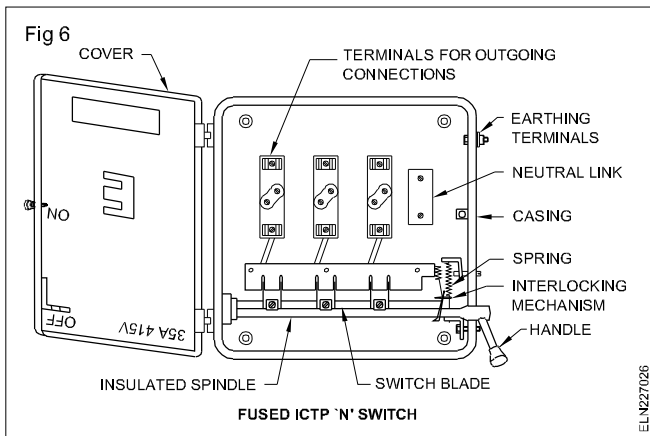

These switches need to be earthed through an earth terminal or screw provided in the outer casing.

The current rating of the switch varies from 16 to 400 amps. Specification of these switches should have

- current rating
- voltage rating
- type of enclosure (sheet steel or cast iron)
- whether with neutral link or otherwise
- rewirable type fuse carriers or HRC type fuse carriers.

Holding accessories

Lamp-holders : A lamp-holder is used to hold a lamp. Earlier, brass holders were most commonly used but nowadays these have been replaced by bakelite holders. These may contain solid or hollow spring contact terminals. Four types of lamp-holders are mainly available.

- Bayonet cap lamp-holders
- Screw type holders
- Edison screw type lamp-holders
- Goliath Edison screw type lamp-holders

According to the Bureau of Indian Standard, 732, clause 5.8, all incandescent lamps, unless hung at a height of 2.5m (8ft), shall be provided with standard bayonet holders for lamps up to and including 200 watts. For lamp powers above 200 W and up to 300 watts Edison screw holders are to be used and for above 300 watts Goliath screw holders are to be used.

Bayonet cap (BC) lamp-holders: In this type, the bulb is fitted into the slot, and is held in position by means of two pins in the lamp cap. It has solid or hollow spring contact

terminals, and the supply mains through the switch are connected to these contacts. In BC types there are two grooves on the circular construction of all types of holders.

The groove and the contact terminals are at right angle to each other. In this type of holders, the lamp is inserted, forced in, turned slightly and then left in position. These holders can be classified further as explained below.

Pendent lamp-holders: This holder (Fig 7) is used in places where the lamps are required in a hanging position. These holders are made of either brass or bakelite. An exploded view of this holder shows the parts of the holder. These holders are used along with ceiling roses for suspending the lamps from the ceiling.

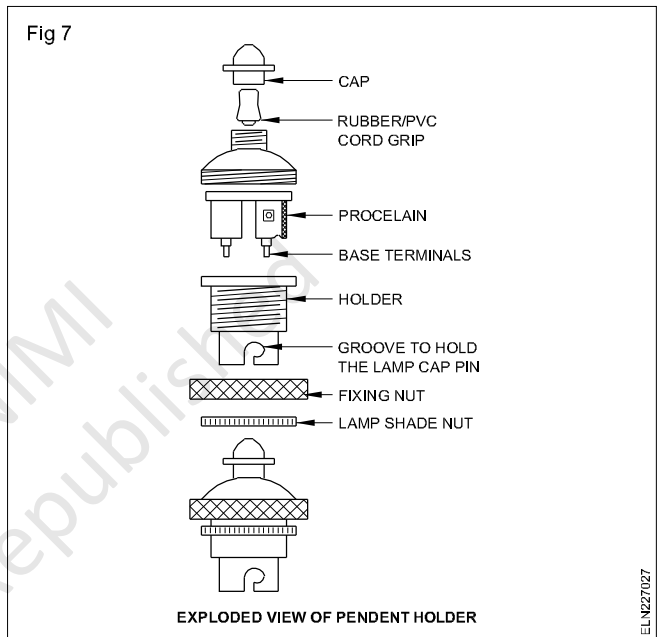

Batten lamp-holders: The straight batten holder (Fig 8a) is used on a flat surface on the round block, wooden board etc. These holders are made of either brass or bakelite.

Angle holders: The angle bottom holder, (Fig 8b) is to hold the lamp in a particular angle. These are made of either brass or bakelite. These are used for advertising boards, window display, kitchens etc.

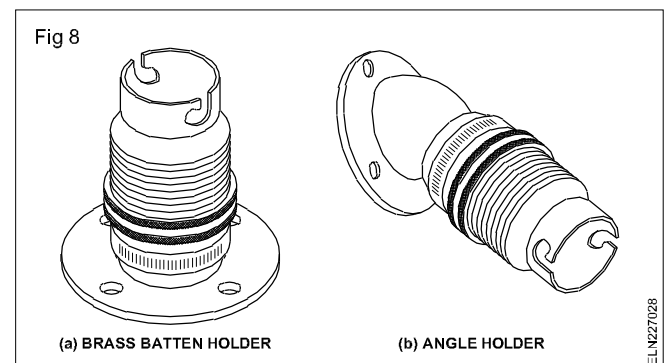

Bracket holders: This holder (Fig 9) is used with a bracket. These are made of brass and are used to give direct light to a particular place. Brass bracket holders need to be earthed as per BIS recommendations.

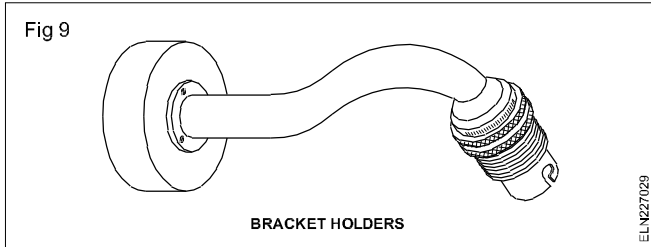

These are fixed on the bracket by the internal threading of the cap.

Tube light or fluorescent lamp-holders and starter-holders: Generally the fluorescent lamp-holders are of a bi-pin type (Fig 10).

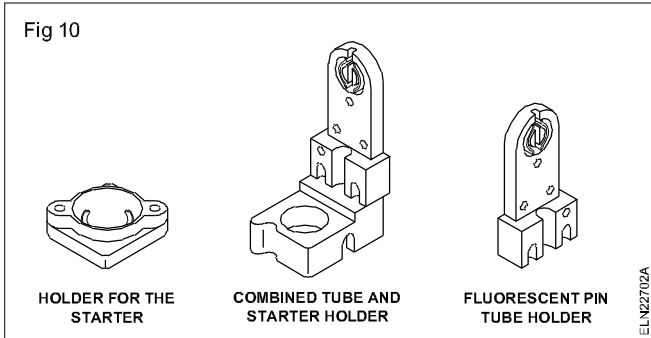

Edison screw-type lamp-holders: In this type, the holder is provided with inner screw threads and the lamp is fitted in it by screwing. It has a centre contact which is connected to the live wire and the screwed cap is connected to the neutral wire.

For lamps with wattage above 200W and not exceeding 300W, Edison screw-type holders are used. Edison screw (ES) lamp holders have spring-loaded central contact to ensure good contact (Fig 11).

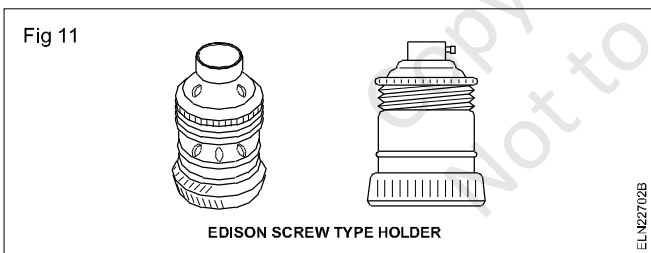

Goliath Edison screw (GES) type holders (Fig 12): The cover of this type of holder is made of porcelain. Such holders are used in studios, headlights, floodlights, focussing lights etc.

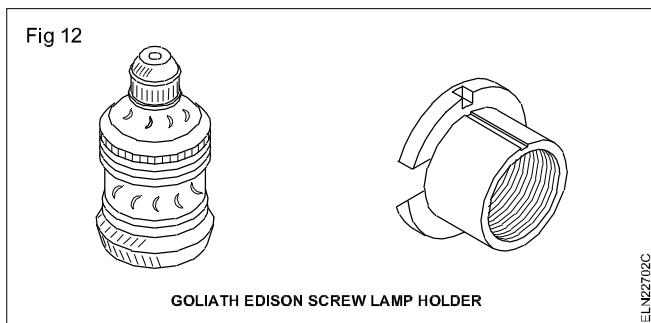

These holders are used for more than 300W lamps.

Swivel lamp-holders: The swivel lamp-holder is designed for wide angle directional lighting which is used for the lighting of shop windows, showcases, etc. It consists of a ball and socket joint fitted between a back plate and the lamp-holders. It is available in bayonet cap type, small bayonet cap type and Edison screw type. All these type of holders are also available for wall fixing patterns or ceiling pattern (Fig 13).

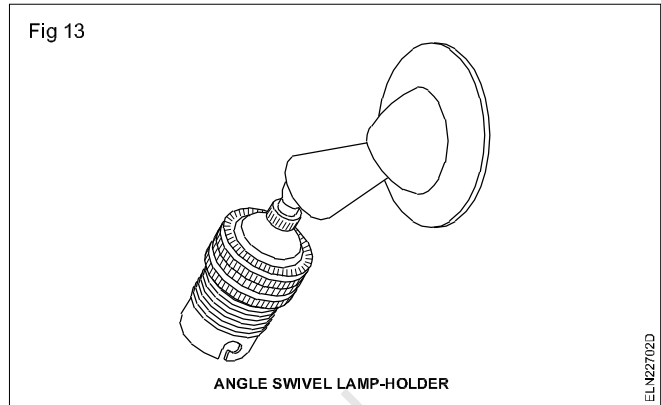

Specification of a lamp-holder: While specifying the lamp-holders, the type of material used for construction, type of gripping, type of mounting, working current and voltages should also be specified.

Safety accessories: A fuse is a safety accessory. It is connected in series with the circuit and protects the electrical apparatus and equipment from damage, when excess current flows.

The kit-kat type fuse is commonly used in domestic installation.

Types of fuses

- Kit-kat type (Rewirable fuse)
- Iron-clad fuse cut out

Kit-kat type fuse: This fuse consists of a porcelain base having two fixed contacts, for connecting the incoming and outgoing cables.

The line and load wires are connected in the base terminals and the carrier is provided with a fuse (Fig 14). The base is fixed but the carrier is removable.

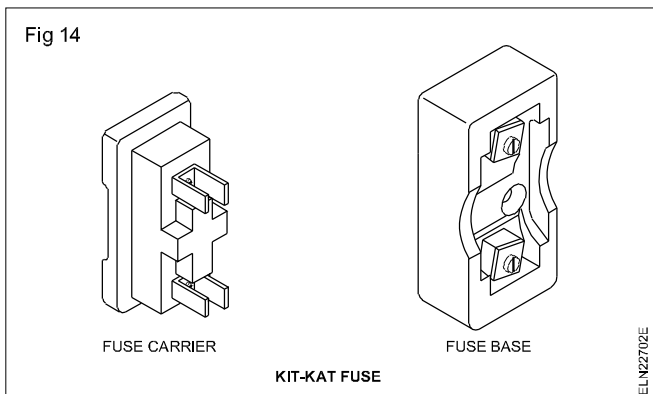

Iron-clad fuse cut outs (Fig 15): These are kit-kat fuses in an iron cover. The iron cover has facility to be closed and sealed with a lead seal. This is used at the incoming side of the power supply and sealed by the supply authorities to ensure the line is not loaded beyond a certain prescribed current capacity.

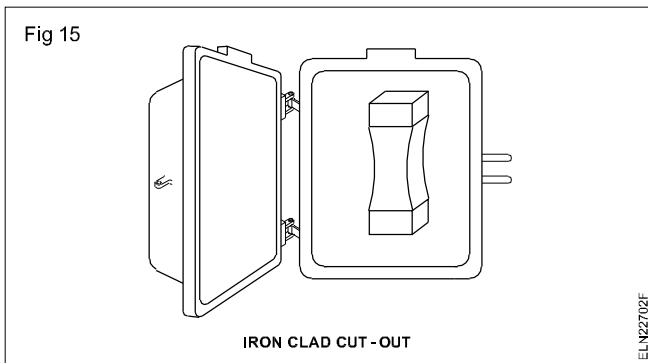

Outlet accessories: These accessories are used to take the supply for the portable appliances like table fans, TV, electric irons etc.

Socket outlet current rating: The standard ratings shall be 6, 16 and 32 amperes and 240 volts. The following types are normally used for domestic purposes. They have to be specified according to the mounting type, number of pins, current capacity and voltage.

Two-pin socket: This socket is rated as 6A, 250V, having only two pins without earth connection. These are suitable only for double insulated appliances (having PVC or insulated body).

Two-pin plug top: It is used for taking the supply from the socket. It has got two pins of the same size.

Three-pin socket: This type of socket is suitable for light and power circuits. These sockets are rated as 6A, 250V or 16A, 250V, and are available as surface-mounting type and flush type (Fig 16). There are three terminals marked as Line (L) Neutral (N) and Earth (E). The line terminal is always on the right hand side, the neutral terminal on the left hand side, and the top is the earth terminal which is larger in diameter. In all the cases, the earth wire must be connected to the earth terminal of the socket.

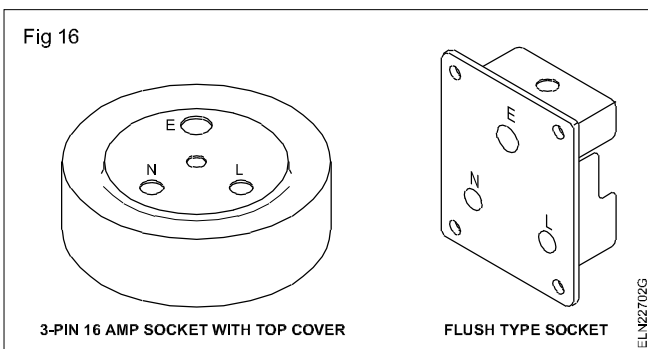

Three-pin plug top : It is used for taking the supply from the socket. It has three pins. Two are similar in size and the third one is bigger and longer which is for earth (Fig 17). These are also rated as 6A, 250V or 16A, 250V. These are made of bakelite, PVC materials.

A socket which is controlled by a switch, is also available. Multi-pin sockets are also available which are suitable for 2 pins and 3 pins having 5 holes in one unit. Further multi-pin sockets for 3 pin of 6 amps and 16 amps are also available having 6 holes in one unit.

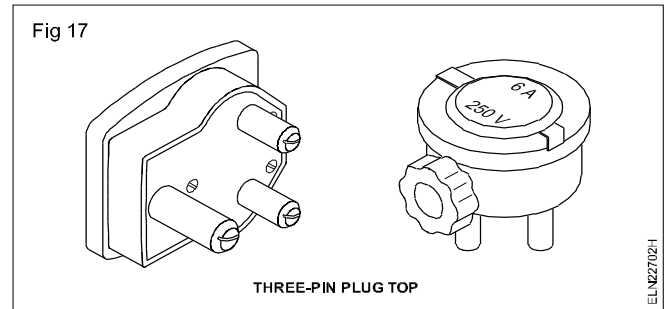

General accessories : Some accessories are used for general and special purposes such as:

- appliance connectors (or) iron connectors
- adapters
- ceiling roses
 - a) two-plate
 - b) three-plate
- connectors
- distribution board
- neutral links.

Appliance connectors or iron connectors : These are used as female connectors to supply current to electric kettles, electric iron, hotplate, heaters etc. It is made of bakelite or porcelain. The wires are connected with two brass terminals and the earth connection is provided with a twin nickel spring. The cable entry has a rubber protection tyre. These are rated as 16A, 250V (Fig 18).

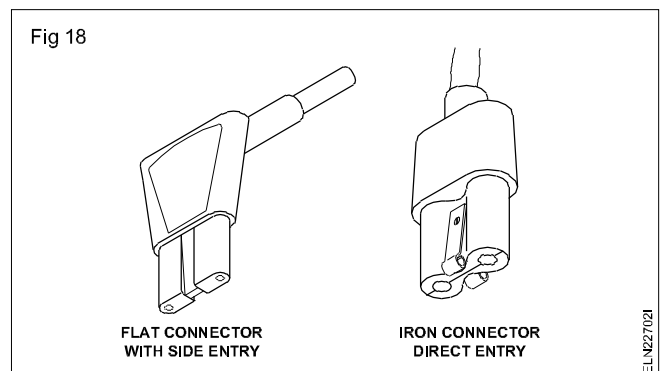

Adaptor (Fig 19): They are used for taking supply from a lamp holder for small appliances. They are made out of bakelite. They are available in ratings up to 6 A 250 V.

Adaptors with multiple plugs are also available for taking supply to a number of appliances from a single point.

These adaptors should not be used in bathrooms or other damp places.

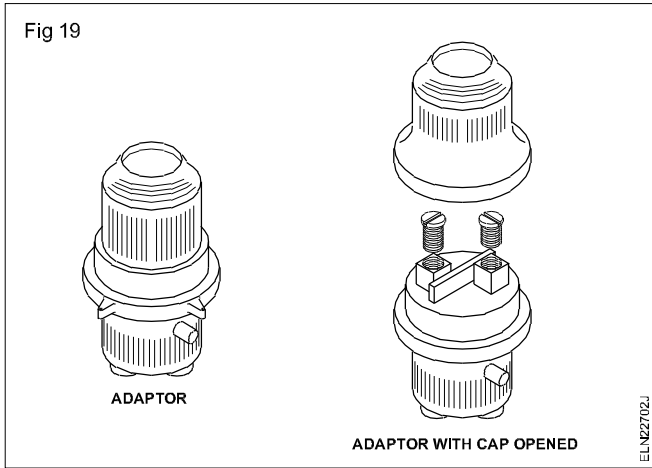

Ceiling roses: Ceiling roses are used to provide tapping points from the wiring for supplying power to fans, pendent-holders, tube lights etc. Normally flexible wires are used for tapping from the ceiling roses.

Ceiling roses have two parts, base and cover, both made of bakelite. The cover has a hole in the centre for the connecting wires to be taken out. There are threadings on the internal sides so that the cover may be fixed or tightened with the base. The base has terminals and holes for fixing on the block etc. and for wires to connect with the supply. Two types of ceiling roses are in use.

Two-plate ceiling rose (Fig 20 a & b): This is made of bakelite and it has 2 terminals (phase & neutral) which are separated from each other by a bakelite bridge. Each of the terminal plates is provided with a metallic sleeve and a binding screw on one side through which the circuit wire from the back via the mounting block enters them. The other side of the terminal plate is provided with a washer and screw to tap wire connection. The two-plate ceiling rose is used for 6A, 250V current capacity. It is not used in circuits whose voltage exceeds 250V.

Three-plate ceiling rose: This type of ceiling rose has 3 terminals which are separated from each other by a bakelite bridge. It can be used for two purposes. (Fig 20 a & c)

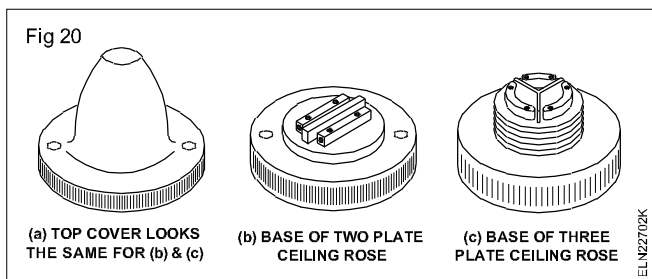

- Bunch light control
- To provide tapping for phase wire (Fig 21).

These ceiling roses are available in the rating of 6A, 250V. The covered 2 plate and 3 plate ceiling roses will look alike but could be identified by seeing the rear side.

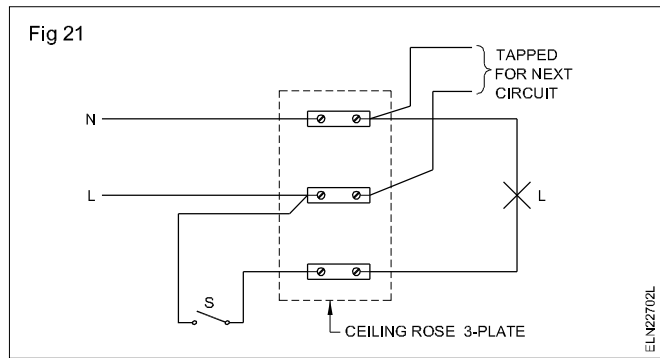

Connectors (Fig 22): Connectors are used to extend the length of the wire without joining. They are made of porcelain, bakelite or PVC based material. There is a brass sleeve with threading for small screws to tighten the wire in the sleeves. These are available in single way, two-way, three-way, six-way, 12-way types. These are rated according to the current and voltage capacity - 6A 250V, 16A 250V, 32A 250V, 16A 500V, 32A 500V etc.

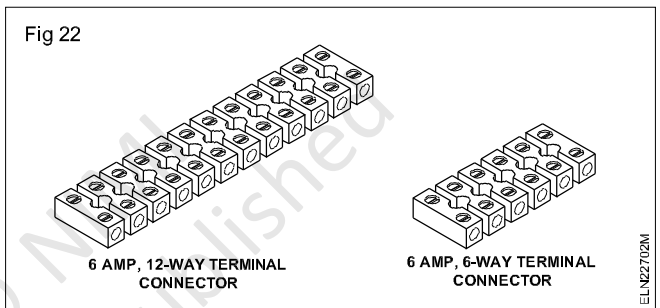

Distribution board (Fig 23): These are used where the total load is high and is to be divided into a number of circuits. These are used where the load is more than 800W. The number of fuses in the board is according to the number of circuits, and a neutral link is also provided so that the neutral wire can be taken for different circuits. All these branch fuses are enclosed in a metal box. These boards are available as two-way, three-way, 4,6,12-way types.

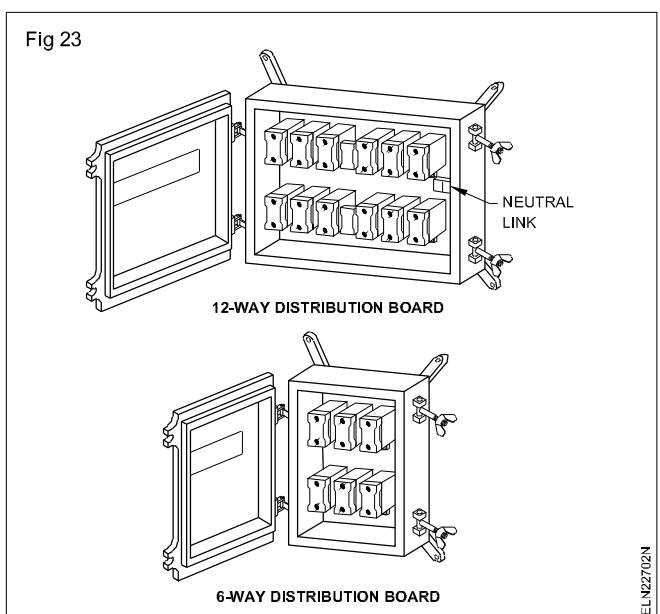

Neutral link: In a three-phase system of wiring installations, the phases are controlled through switches, and the neutral is tapped through a link called neutral link. The neutral link consists of a terminal for incoming current and a multi-way outgoing circuit. The metal terminals are mounted on high grade vitreous porcelain base (Fig 24). The ratings are 16A, 32A, 63A, 100A neutral link.

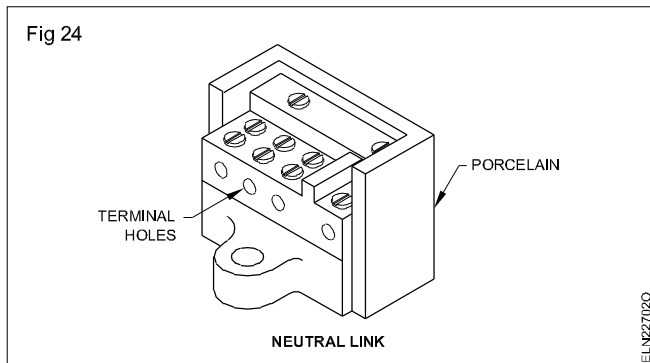

The accessories' rating shall be 240V and 6 or 16 amps from the year 1991, instead of 250V and 5 or 15 amps as per BIS 1293-1988.

Toggle switches (Fig 25)

It is an electric switch operated by means of a projecting lever that can be moved upward and downward and is also called as snap switches .

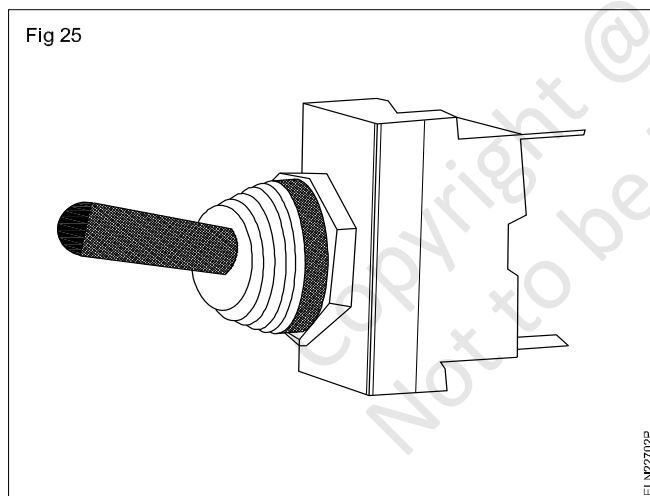

The toggle switches are generally specified based on

- Number of poles (single / double/ triple etc.)
- Number of throws (single / double/ double with center OFF etc.)
- Current rating (3,6,10,16,20 & 25A)
- Voltage rating (125V & 250V , AC)
- Size (8,10,12,15mm etc.)
- Knob type (Brass/ plastic and oval/ round/flat etc.)

Modular switches

The latest version of modular switch of different sizes and colours along with sockets combined and switches with indicators are available in market (Fig 26).



Indian Electricity Rules - Safety Requirements

The IE rules 1956 was made under sections 37 of Indian Electricity Act 1910. Now it is redefined after the enactment of the Electricity Act 2003. The Central Electricity Authority (measures relating to safety and electric supply) Regulation (CEAR) 2010 which came into effect from 20th September 2010, in place of Indian Electricity Rules 1956.

SAFETY RULES: Among safety rules, the following are important and indeed requires attention. Every rule in the Indian Electricity Rules 1956 is related either directly or indirectly to safety.

Rule 32: Switches shall be on the live conductor. No cutout, link or switch other than gang switch shall be inserted in the neutral conductor. Code of Practice of wiring shall be followed while marking the conductors.

Rule 50: Energy shall not be supplied, transformed, converted or used unless the following provisions are observed. A suitable linked switch or circuit breaker is erected at the secondary side of the transformer. Every circuit is protected by a suitable cut-out. Supply to each motor or group of motors is controlled by a linked switch or circuit breaker. Adequate precautions are taken to ensure that no live parts are exposed.

Special provisions in respect of high and extra high voltage installations

Rule 63: Approval of Inspector is necessary before energising any high voltage installations.

Rule 65: The installation must be subjected to the prescribed testing before energizing.

Rule 66: Conductors shall be enclosed in a metallic covering and suitable circuit breakers shall be provided to protect the equipment from overloading.

Rule 68: In case of outdoor type of sub-station a metallic fencing of not less than 1.8 m height shall be erected around the transformer.

Provisions in terms of OH line

Rule 77: Clearance of lowest conductor above ground across street.

- Low and Medium Voltage lines - 5.8 m.
- High voltage Lines - 6.1 m.
- Clearance of lowest conductor above ground along a street. Low and Medium Voltage lines - 5.5 m.
- High voltage lines - 5.8 m.
- Clearance of lowest conductor above ground other than along or across the street. Low, Medium and High Voltage lines upto 11 KV if bare - 4.6m .
- Low, Medium and High upto and including 11KV, if insulated - 4.0m.
- High Voltage above 11 KV - 5.2 m.

Rule 79: Clearance of low and medium voltage lines from building,

- Vertical Clearance - 2.5 m.
- Horizontal clearance - 1.2 m.

Rule 80: Clearance from building of high and extra high voltage. Vertical Clearance High Voltage upto 33KV - 3.7m.

- Extra High Voltage above 33KV - 3.7 m, plus 0.3 m for every 33KV part there of.
- Clearance from building of high and extra high voltage - Pitched Roof . Vertical Clearance upto 11KV - 1.2m.
- Above 11KV upto 33KV - 2.2 m.
- Above 33KV - 2m. plus 0.3m for every 33KV part there of.

Rule 85: Maximum interval between supports. It shall not exceed 65 m except by prior approval of inspector.

Indian electricity rules regarding to internal wiring:

- 1 The minimum size of conductor used in domestic wiring must not be of size less than 1/1.12mm in copper or 1/1.40mm (1.5mm) in aluminium wire.

- 2 For flexible wires the minimum size is 14/0.193mm.
- 3 The height at which meter board, Main switch board are to be fitted 1.5 meters from ground level.
- 4 The casing will be run at a height of 3.0 meters from the ground level.
- 5 The light brackets should be fixed at a height of 2 to 2.5 meters from ground level.
- 6 The maximum number of points in a sub circuit is 10.
- 7 The maximum load in a sub circuit is 800W.

I.E. Rules regarding - Voltage drop concept:

- 1 **I.E. Rule 48:** The insulation resistance between the wiring of an installation and earth should be of such a value that the leakage current may not exceed 1/50000 the part or 0.02 percent of the F.L. current.
- 2 The permissible voltage drop in a lighting circuit is 2% of the supply voltage plus one volt.
- 3 The maximum permissible voltage drop in a power industrial circuit should not be more than 5% of the declared supply voltage.
- 4 The insulation resistance of any wiring installation should not be less than 1M Ω .
- 5 The earth resistance should not exceed the value of one ohm.

I.E. Rules regarding to power wiring:

- 1 In a power sub circuit the load is normally restricted to 3000 watts and number of outlets to two in each sub circuit.
- 2 All equipment used in power wiring shall be iron clad construction and wiring shall be of the armoured cable or conduit type.
- 3 The length of flexible conduit used for connections between the terminal boxes of motors and starters, switches and motors shall not exceed 1.25 meters
- 4 Every motor, regardless of its size shall be provided with a switch fuse placed near it.
- 5 The minimum cross-sectional area of conductor, that can be used for power wiring of 1.25 mm for copper conductor cables and 1.50 mm for Aluminium conductor cables (refer ISI recommendations). Hence VIR or PVC cables of size lower than 3/0.915 mm copper or 1/1.80 mm Aluminium can not be used for motor wiring.

Circuit Breaker (CB) - Miniature Circuit Breaker (MCB)- Moulded Case Circuit Breaker (MCCB)

Objectives: At the end of this lesson you shall be able to

- explain the types, working principle and parts of a miniature circuit breaker.
- state the advantages and disadvantages of MCB
- explain the working of combination circuit breaker (ELCB + MCB)
- state the categories and applications of MCBs
- state the application, advantage and disadvantage of MCCBs.

Circuit Breaker

A circuit breaker is a mechanical switching device capable of making, carrying and breaking the currents under normal condition and breaking the currents under abnormal conditions like a short circuit.

Miniature circuit breaker (MCB)

A miniature circuit breaker is a compact mechanical device for making and breaking a circuit both in normal condition and in abnormal conditions such as those of over current and short circuit.

Types of MCB's

MCBs are manufactured with three different principles of operation namely

- a Thermal Magnetic
- b Magnetic hydraulic and
- c Assisted bimetallic

Thermal magnetic MCB

The switching mechanism is housed in a moulded housing with phenolic moulded high mechanically strong switching dolly. This type of MCB is also provided with bimetallic overload release (Fig 1).

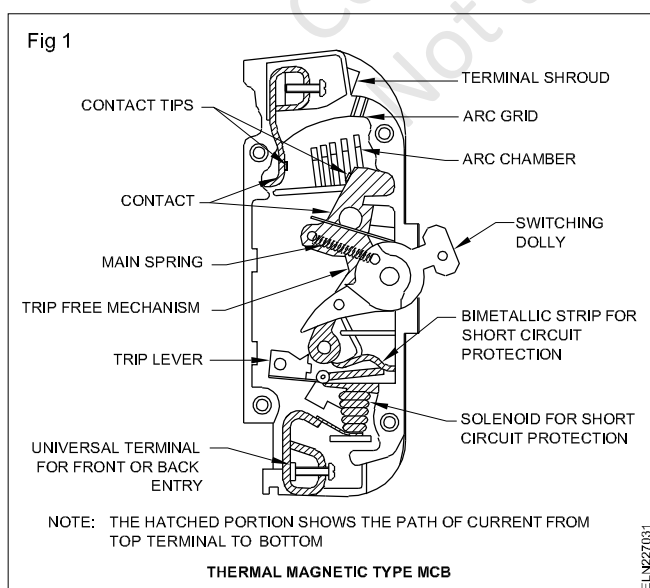

The electric current gets through two contact tips one each on moving and fixed contact of silver graphite.

An arcing chamber incorporating de-ionising arc chutes for control and quick suppression of the arc is provided in the gap between two contacts. It has a ribbed opening closed by metal grid which allows ventilation and escape of gases.

For protection against over-load and short circuit, MCB's have thermal magnetic release unit. The overload is taken care of by bimetallic strip, short circuit currents and over loads of more than 100% are taken care by solenoid.

Working

The bimetallic strip when flexing due to temperature rise caused by increasing normal rated current beyond 130% rotates a trip lever carrying an armature to which it is brought into field of a solenoid. The solenoid is designed to attract the armature to full position at about 700% overload or instantaneous short circuit current.

For initial portion of current wise (130% to 400%) tripping of circuit breaker is due to thermal action, between 400 to 700% tripping is due to combined thermal and magnetic action and beyond 700% due to fully magnetic action.

Magnetic hydraulic MCB

Magnetic hydraulic circuit breaker operates on the principle of a solenoid and hydraulically damped plunger.

Construction and working

A movable ferrous plunger is held against a non-ferrous tube containing polysiloxane liquid which have flat temperature viscosity characteristic in temperature range of 20 to 60°C. The solenoid is a series coil in the circuit of MCB. As the plunger moves towards a pole piece, the reluctance of magnetic path.

Containing the armature is cumulatively reduced leading to some magneto motive force producing a progressively increasing flux. The armature is then attracted causing the mechanism to trip and open the controls on overload or short circuit (Fig 2). Instantaneous tripping occurs on very large currents 7 to 8 times the full load current. The construction of magnetic hydraulic tripping mechanism is in Fig 2.

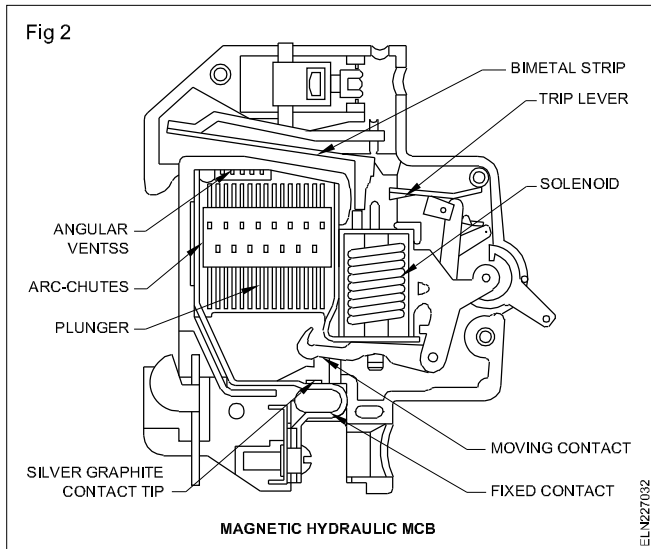

Assisted Bimetal Tripping MCB (Fig 3)

In the assisted bimetal form of construction, the time delay characteristic is provided by a thermally operated bimetal element which may be either directly or indirectly heated. Instantaneous tripping in short circuit condition is achieved by arranging a powerful magnetic pull to deflect the bimetal (Fig 4).

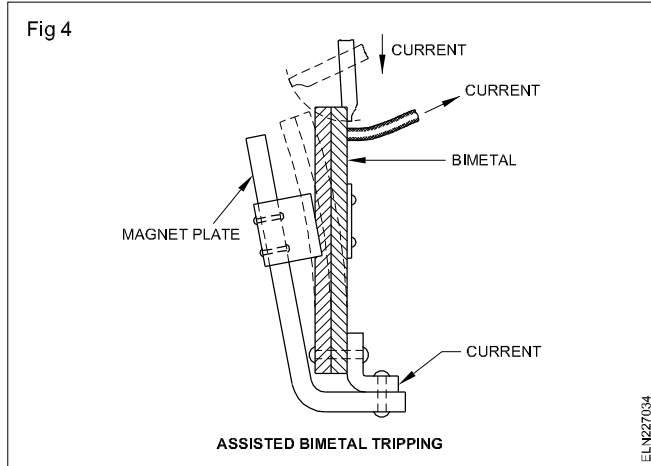
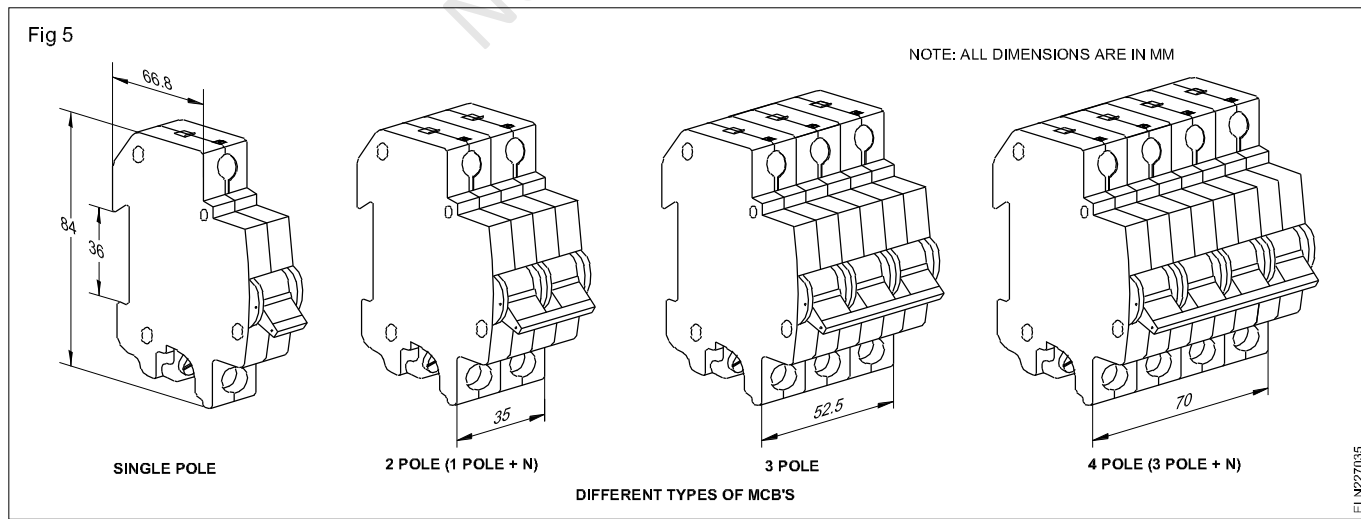
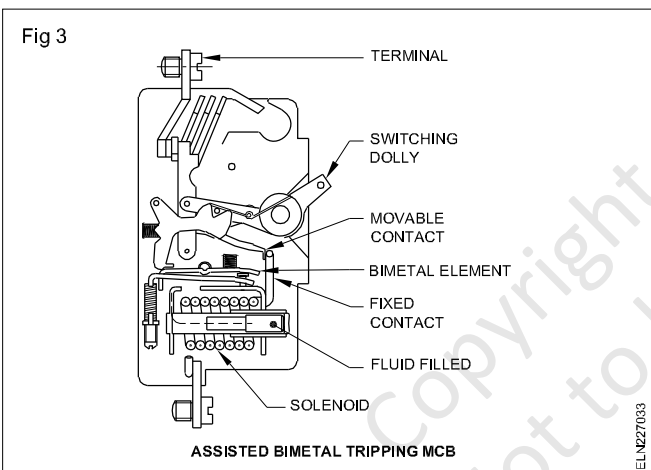

This method utilises the magnetic field which is produced when a current flows through the conductor. By locating the bimetal near to a substantial section of ferrous material, the magnetic field associated with current flowing in the bimetal will cause a sideways pull to be applied to the bimetal element, attracting the bimetal towards the ferrous material.

This sideways pull is arranged to coincide in direction with the normal direction of movement of the bimetal, which is powerful enough to deflect the bimetal (in heavy over load or short circuit condition) sufficiently to trip the breaker.

Design and rating of MCBs

MCBs are normally rated for 25°C ambient temperature and are available in the following various combination of poles and current ratings (Fig 5).

Sl.No.	No. of poles	Current
1	Single pole MCB	0.5 to 60A
2	Double pole MCB (ie. 2 MCBs with common trip bar)	5 to 60A
3	Triple pole MCB	5 to 60A
4	Four pole MCB	5 to 60A

Isolators

An isolator is a switch. These cannot be used for automatic tripping. Isolators are not meant for either closing or breaking the circuit on load or short circuit. Isolators have the same physical dimensions of MCBs and are available in the following configurations and ratings.

No. of poles	Current rating
Single pole	30, 60, and 100A
Single pole with Neutral	30, 60, and 100A
Triple pole	60, and 100A
Four pole	60 and 100A

ELCB + MCB combination circuit breaker

Now a days some manufacturers have introduced an ELCB + MCB combination circuit breaker which can be used instead of using separate MCB and ELCB (earth leakage circuit breaker). This combination not only allows reduction in costs, but also ensures

- over current
- short circuit
- earth leakage
- earth fault.

Earth leakage circuit breakers are now generally called Residual Current circuit breakers (RCCB).

The rated load currents of the RCCB + MCB combination are 6A, 10A, 16A, 20A, 25A, 32A and 35A. The bimetal trip is so adjusted that no tripping will occur upto 1.3 times the rated current.

Categories of MCBs

Certain manufacturers like Indo Kopp manufacture the MCBs in three different categories namely 'L' series, 'G' series, and 'DC' series.

'L' series MCBs

'L' series MCBs are designed to protect circuits with resistive loads. They are ideal for protection of equipment like Geysers, ovens and general lighting systems.

'G' series MCBs

'G' series MCBs are designed to protect circuits with inductive loads. G series MCBs are suitable for protection of motors, air conditioners, hand tools, halogen lamps etc.,

'DC' series MCBs

'DC' series MCBs are suitable for voltage upto 220V DC and have a breaking capacity up to 6kA.

The tripping characteristics are similar to 'L' an 'G' series. They find extensive application in DC controls, locomotives, diesel generator sets etc.,

Advantages of MCB

- 1 Tripping characteristic setting can be done during manufacture and it cannot be altered.
- 2 They will trip for a sustained overload but not for transient overload.
- 3 Faulty circuit is easily identified.
- 4 Supply can be quickly restored.
- 5 Tamper proof.
- 6 Multiple units are available.

Disadvantages

- 1 Expensive.
- 2 More mechanically moving parts.
- 3 They require regular testing to ensure satisfactory operation.
- 4 Their characteristics are affected by the ambient temperature.

Application of (RCCB + MCB) combination circuit breakers

- 1 All residential premises can have incoming protection after energy meter instead of fixing fuse and main switch.
- 2 All domestic equipments like water heaters, washing machines, electric iron, pump sets etc.,
- 3 All construction and outdoor electrical equipments such as lifts, hosts, vibrators, polishing machines etc.,
- 4 All industrial distribution and equipments
- 5 All agriculture pump sets.
- 6 Operation theatres and electrically operated medical equipment such as X-ray machines.
- 7 All neon sign installations
- 8 All low and medium voltage electrical distributions.

Technical specification of MCBs

Related voltage	240/ 415V AC 50Hz Up to 220V DC
Current rating	0.5, 1, 1.6, 2, 2.5, 3, 4, 5, 6, 7.5, 10, 16, 20, 25, 32, 35, 40 and 63A.
No. of poles	1,2,3
Types	'L' 'G' and 'DC' series
Breaking capacity	UP to 9kA
Mechanical life	1,00,000 operations
Electrical life	50,000 operations
Overload capacity	15% over load
Housing	Glass fiber reinforced polyester
Fixing	Snap fixing on 35 mm DIN channel
Types of terminals	25mm ² box type terminal at the incoming and outgoing.

Definition of Breaking capacity of MCB

The short circuit breaking capacity of the circuit breaker is the current more than the prospective fault current at the point of installation of circuit breaker. Prospective fault current is the maximum fault current which may have to be interrupted by the circuit breaker.

Moulded Case Circuit Breakers (MCCB)

Moulded case circuit breakers are similar to thermo magnetic type MCBs except that these are available in higher ratings of 100 to 800amp at 500V 3-phase.

ELCB - types - working principle - specification

Objectives : At the end of this exercise you shall be able to

- explain the working principle, different types and construction of an earth leakage circuit breaker (ELCB)
- explain the technical specifications of ELCB's.

Introduction

The sensation of electric shock is caused by the flow of electric current through the human body to earth. When a person comes in contact with electrically live objects like water heaters, washing machines electric iron etc., the extent of damages caused by this current depends on its magnitude and duration.

This kind of current is called the leakage current which comes in milli-amps. These leakage current being very small in magnitude, hence undetected by the fuses/MCBs are the major cause for the fires due to electricity.

The leakage current to earth also results in the wastage of energy and excessive billing for electricity not actually used.

In MCCB, thermal and magnetic releases are adjustable. A shunt release is also incorporated for remote tripping and interlocking at MCCB. MCCBs are provided with under voltages release. There are two types of MCCB.

- 1 Thermal magnetic type.
- 2 Fully magnetic type (Fig 6).

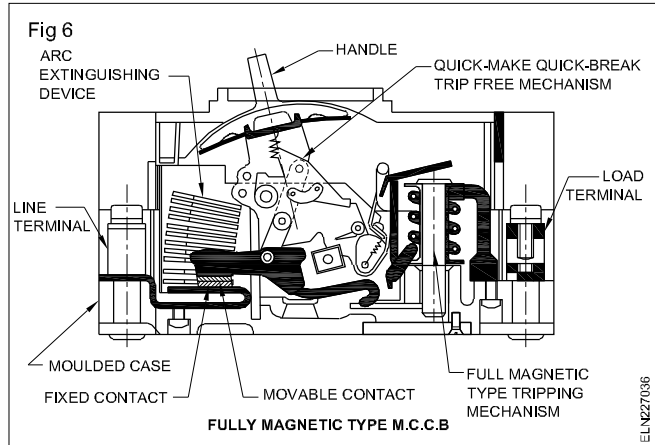

Advantages of MCCB

- 1 MCCBs occupy much less space in comparison to fuse switch units.
- 2 MCCBs provide equal amount of protection against high faults as switch gears having HRC fuses.

Disadvantages

- 1 MCCBs are much costlier.
- 2 Leak proof situation required.
- 3 Sensitivity to insulation resistance low.

Residual current operated circuit breakers are inter-nationally accepted means of providing maximum protection from electric shocks and fires caused due to earth leakage current and also prevents the waste of electrical energy. These residual current circuit breakers (RCCB) are popularly called as Earth leakage circuit breakers (ELCB). The effect of electric current on human body in various levels represented in graph (Fig 1).

Basically ELCBs are of two types namely voltage operated ELCBs and the current operated ELCBs.

Voltage operated ELCB

This device is used for making and breaking a circuit. It automatically trips or breaks the circuit when the potential difference between the protected metal work of the installation and the general mass of earth exceeds 24V. This voltage signal will cause the relay to operate (Fig 2).

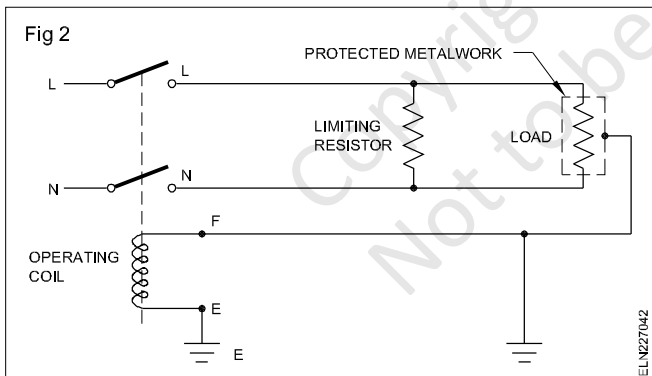
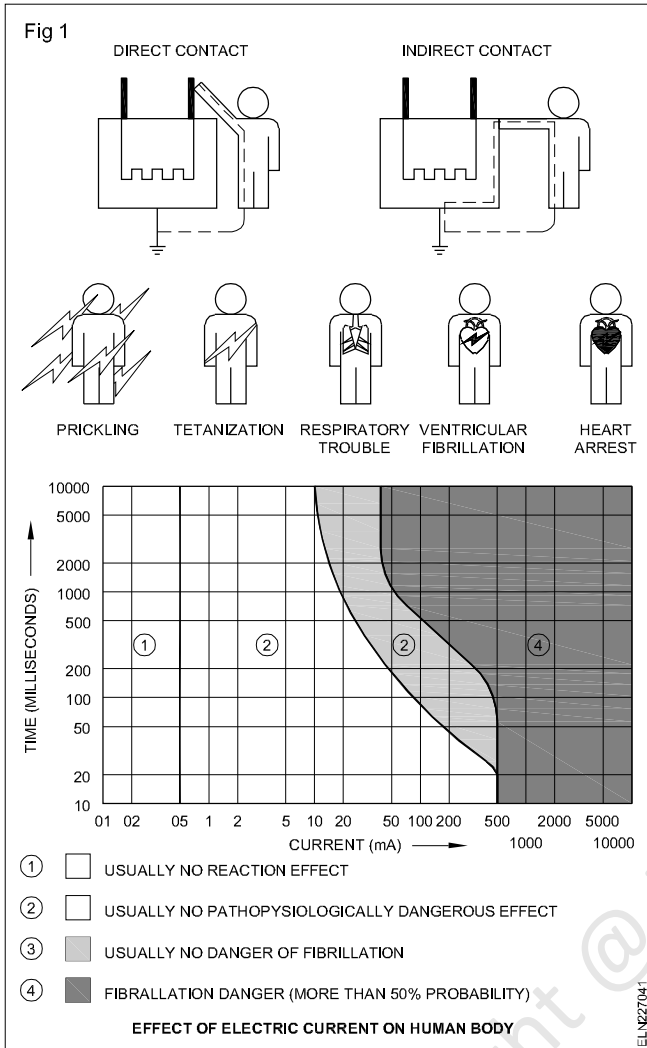

Voltage operated ELCBs are meant to be used where it is not practicable to meet the requirements of IEE wiring regulation by direct earthing or where additional protection is desirable.

Current operated ELCB

This device is used for making and breaking a circuit and for breaking a circuit automatically when the vector sum of current in all conductors differs from zero by a predetermined amount. Current operated ELCBs are much more reliable in operation, easier to install and maintain.

Construction of current operated ELCB

It consists of a Torroid ring made of high permeability magnetic material. It has two primary windings each carrying the current flowing through phase and neutral of the installation. The secondary winding is connected to a highly sensitive electro-magnetic trip relay which operates the trip mechanism.

Working principle

The residual current device (RCD) is a circuit breaker which continuously compares the current in the phase with that in the neutral. The difference between the two is called as the residual current which is flowing to earth.

The purpose of the residual current device is to monitor the residual current and to switch off the circuit if it rises from a preset level (Fig 3).

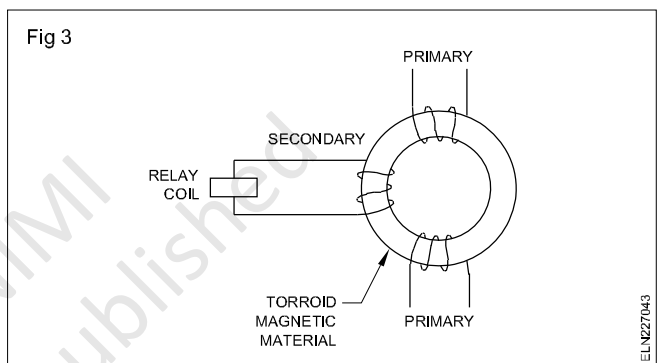

The main contacts are closed against the pressure of a spring which, provides the energy to open them when the device trips. Phase and neutral current pass through identical coils wound in opposing direction on a magnetic circuit, so that each coil will provide equal but opposing numbers of ampere turns when there is no residual current. The opposing ampere turns will cancel and no magnetic flux will be set up in the magnetic circuit.

In a healthy circuit the sum of the current in phases is equal to the current in the neutral and vector sum of all the current is equal to zero. If there is any insulation fault in the circuit then leakage current flows to earth. This residual current passes to the circuit through the phase coil but returns through the earth path and avoids the neutral coil, which will therefore carry less current.

So the phase ampere turns exceeds neutral ampere turns and an alternating magnetic flux results in the core. The flux links with the secondary coil wound on the same magnetic circuit inducing an emf into it. The value of this emf depends on the residual current, so it drives a current to the tripping system which depends on the difference between them and neutral current.

When tripping current reaches a predetermined level the circuit breaker trips and open the main contacts and thus interrupts the circuit. A 3-phase 4 wire electric system can also be protected by providing a 4 pole RCCB (Fig 4).

Fig 4

4 POLE VERSION FOR 3PHASE - 4 WIRE CONNECTIONS

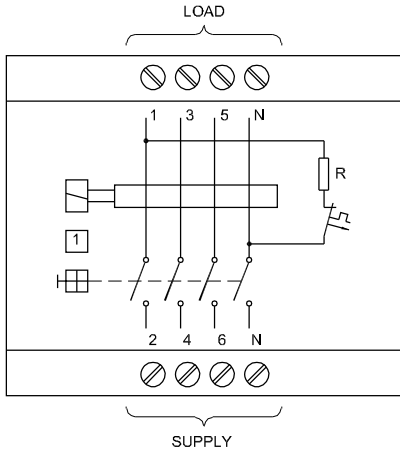

2 POLE VERSION FOR SINGLE PHASE - 2 WIRE CONNECTIONS

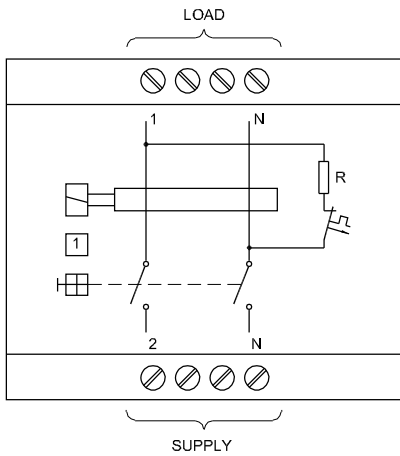

Test Switch

A test switch is a requirement as per BS842 (Fig 5). It is used to test the functioning of ELCB. When the test button is pressed it circulates additional current through neutral coil which is determined by the value of current limiting resistor R. As a result there exists a difference in current flowing through phase and neutral coils and hence the ELCB trips OFF.

Fig 5

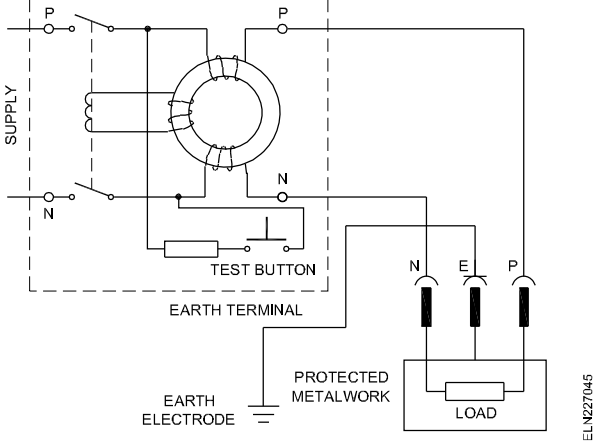

Technical specification

The current ratings of ELCB are 25A, 40A and 63A.

No. of poles - 2 and 4

Nominal voltage - 240/415V 50Hz.

Sensitivities: ELCBs are designed to trip at leakage currents of 30mA, 100mA, and 300mA.

Electrical life: More than 10,000 operations.

Mechanical life:

20000 to 100000 operations.

Tripping time - < 30ms.

Time delayed RCCB

There are cases, where more than one RCCB is used in an installation, for example a complete installation may be protected by an RCCB rated at 100mA, while a socket intended for equipment may be protected by 30mA device.

Discrimination of the two devices then becomes important. For example an earth fault occurs in the equipment giving an earth fault current of 250mA. Since the fault current is higher, than the operating current of both devices, both will trip.

It does not follow, that the device with smaller operating current will trip first. This is a lack of discrimination between the two devices. To ensure proper discrimination, the device with a larger operating current, has a deliberate time delay built into its operation. It is called time-delayed RCCB. Images of 2 pole and 4 pole ELCB are given below (Fig 6).

Earth fault loop impedance

Earth wire from an equipment to the earth electrode is called earth loop. Earth fault loop impedance (Z_E) is the impedance of the fault current path. It must be low enough to ensure that the productive devices like ELCB will operate within the specified time.

In any case, the multiplication value of earth fault loop impedance in Ohms and the rated tripping current (I_t) in ampere of ELCB should not exceed 50V .

$$Z_E \times I_t < 50V.$$

Fig 6



a) 2-POLE ELCB



b) 4-POLE ELCB

ELN227046

Fuses

Objectives: At the end of this lesson you shall be able to

- explain the purpose of the fuse in a circuit
- classify the different types of fuses and their uses.

Purpose of fuses: A fuse is a safety device used for the purpose of protecting a circuit against excess current. In the event of excessive current, the fuse element melts and opens up the circuit thereby protecting it from damage.

Symbols: These are the graphical symbols used to illustrate an electrical fuse in electro-technical diagrams.

- General symbols of a fuse (Fig 1a)
- Fuse with terminals and protective housing (Fig 1b)

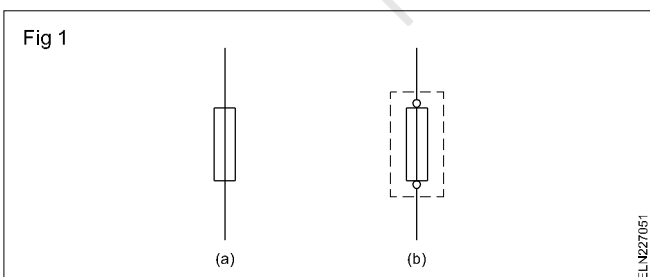

ELN227051

Placement of fuses: In electrical installations, the fuses are always connected into the live wires (Fig 2) and never into the neutral N or the protective earth line PE.

Terminology

Fuse element: The part of the fuse which is designed to melt and open up a circuit.

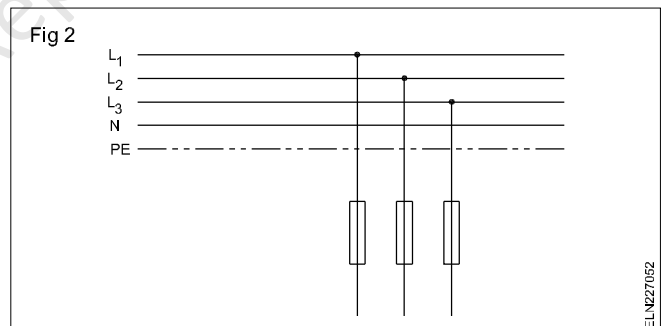

ELN227052

Fuse-carrier: The removable portion for carrying the fuse element.

Fuse base: The fixed part of the fuse provided with terminals for connection to the circuit which is suitable for the reception of the fuse-carrier.

Current rating: Safe maximum current that can pass continuously without overheating.

Fusing current: The current at which the fuse element melts.

Cut-off factor: Time (period) taken by a fuse to interrupt the circuit in the event of a fault.

Fusing factor: Ratio between minimum fusing current and current rating.

$$\text{Fusing factor} = \frac{\text{Minimum fusing current}}{\text{Rated current}}$$

The fusing factor for a re-wirable fuse varies between 1.4 to 1.7 and may go up to 2.0, but for a HRC fuse it is 1.1

However, a fuse selected for over-current protection should not have a fusing factor of more than 1.4.

Types of fuses used in domestic wiring:

- Re-wirable type (up to 200A)
- Cartridge type (up to 1250A)

Rewirable type fuse (Fig 3): The fuse element in this type of fuse consists of a wire which may be replaced when necessary. These fuses are simple in construction and the initial cost as well as the renewal cost is very low.

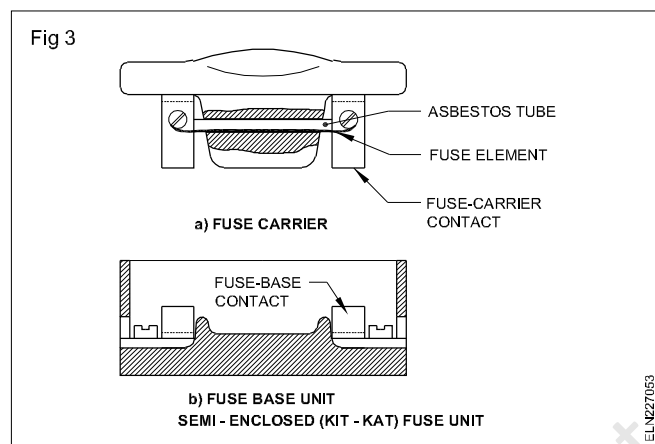

The fuse elements used in this type are tinned copper wire, lead and tin alloy or aluminium wire (Table 1).

The fuse element will melt after approximately 2 minutes when carrying a current equal to twice the current rating. However, the cut-off time factor varies in rewirable fuses due to:

- the construction of the carrier (design of fuse-carrier/ base)
- the manner in which the fuse wire has been fitted
- the length of time the fuse was in service
- ambient temperature
- the amount of current etc.

Small fuse wires in parallel in a carrier to carry a large current should be avoided, as far as possible. The actual rating becomes less than the sum of the ratings of the individual strands. A paralleling factor of 0.7 to 0.8 is used to multiply the sum of the rating of individual strands to get the actual current rating.

Example: 35 SWG - copper wire has a fuse rating of 5 amps, and 3 strands in parallel together will have current rating equal to $5 \times 3 \times 0.8 = 12$ amps when 0.8 is taken as the paralleling factor.

Table 1

Current rating for	Approximate fusing current Amp	Tinned copper wire		Aluminium wire dia. in mm
		S.W.G.	Diameter in mm	
1.5	3	40	.12192	--
2.5	4	39	.13208	-
3.0	5	38	.1524	.195
4.0	6	37	.17272	-
5.0	8	35	.21336	-
5.5	9	34	.23368	-
6.0	10	33	.254	.307
7.0	11	32	.27432	-
8.0	12	31	.29464	-
8.5	13	30	.31496	-
9.5	15	-	---	.400
10.0	16	29	.34544	-
12.0	18	28	.37592	-
13.0	20	-	---	.475
13.5	25	-	---	.560
14.0	28	26	.4572	-
15.0	30	25	.508	.630
17.0	33	24	.5588	-
18.0	35	-	---	.710
20.0	38	23	.6096	--
21.0	40	-	---	-
22.0	45	-	---	.750
24.0	48	22	.7112	.850
25.0	50	-	---	.90
29.0	58	21	.8128	-
30.0	60	-	---	1.00
34.0	70	20	.9144	1.22
37.5	80	-	---	1.25
38.0	81	19	1.016	--
40.0	90	-	---	1.32
43.0	98	-	1.1176	-
43.5	100	-	---	1.40
45.0	106	18	1.2192	-
55.0	120	-	---	1.60
62.0	130	-	---	1.70
65.0	135	17	1.4224	-
66.0	140	-	---	1.80
69.0	150	-	---	1.85
73.0	166	16	1.6256	-
75.0	175	-	---	2.06
78.0	197	15	1.8288	-
80.0	200	-	---	2.24
102.0	230	14	2.032	-

Disadvantages of rewirable type fuse:

- Deterioration of the fuse element by oxidation due to heating.
- Lack of discrimination.
- Effected by the fluctuation of the ambient temperature.
- Premature failure due to deterioration under normal load.
- Low speed operation (poor cut - OFF factor).
- External flash or arc on blowing.
- Poor rupturing capacity (under short-circuit condition).
- Wrong rating possible by human error.

Rewirable-type fuses up to 16A rated current should not be used in locations where short circuit level exceeds 2 KA, (I.S. 2086-963).

Cartridge fuses: Cartridge fuses are developed to overcome the disadvantages of the rewirable fuses. As cartridge fuse elements are enclosed in an air tight chamber, deterioration does not take place. Further the rating of a cartridge fuse could be accurately determined from its marking. However, the cost of replacement of cartridge fuses is more than that of rewirable fuses.

Cartridge fuses can be grouped as those with a:

- low rupturing capacity (Say rupturing capacity up to 50 KA.)
- high rupturing capacity. (Say rupturing capacity above 80 KA.)

Rupturing capacity is the ability of a fuse to open the faulty circuit without much arcing or damage to itself. For domestic installations, low rupturing capacity fuses are used whereas for power installations, high rupturing capacity (HRC) fuses are used.

Low rupturing capacity cartridge fuses can be further divided into:

- Ferrule-contact cartridge fuses (Fig 4).
- diazed screw-type cartridge fuses (Fig 5).

Ferrule-contact cartridge fuses: This type, is used for protecting electrical and electronic circuits. These are available in 25, 50, 100, 200, 250, 500 milliamperes, and also in 1,2,5,6,10,16 & 32 amperes capacity.

Normally the current rating is written on one side of the cap, and while replacing, the same capacity fuse should be used. Its body is made of glass and the fuse wire is connected between two metallic caps.

This fuse can be plugged into the fuse socket (Fig 4a) or it can be fitted into a fuse base with a screw, type fuse- holder (Fig 4b).

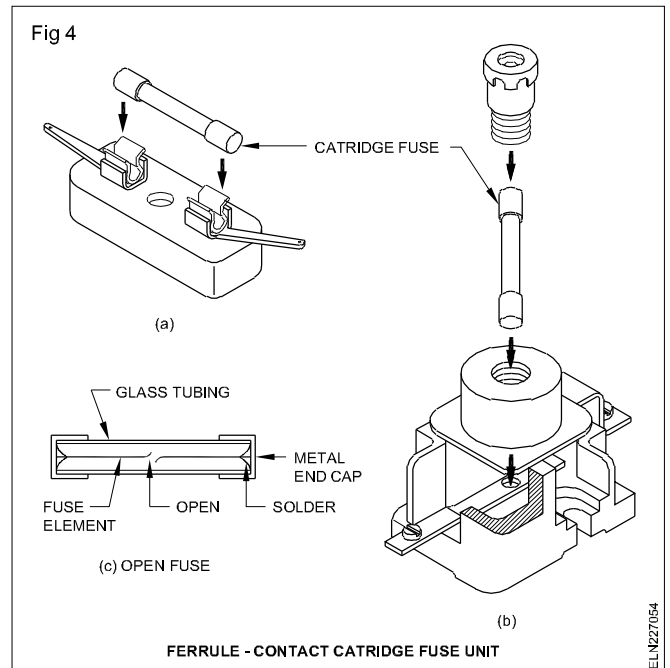

Diazed screw-type cartridge fuses: This type of fuse is commonly used in domestic and industrial electrical installations . It consists of the following parts Fig 5.

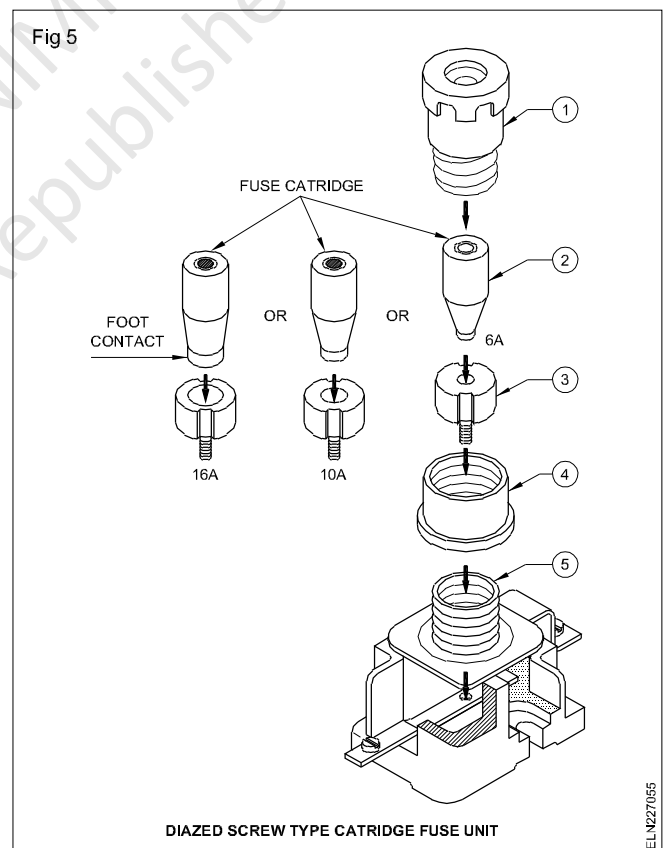

- Screw cap or fuse cartridge-holder(1)
- Fuse cartridge(2)
- Fitting screw or contact screw(3)
- Protective plastic or ceramic ring(4)
- Fuse base or fuse socket(5)

Fuse cartridges are available for rated electric currents of: 2-4-6-10-16-20-25-32-50 and 63 amperes. To prevent the insertion of a fuse cartridge having a larger current rating than intended, the foot contacts of the fuse cartridges have different diameters for each rated current (the smaller the current the smaller the diameter of the foot contact). As there is also a separate fitting screw for each type of cartridge, it is not possible to insert, let's say, a 32 amp. fuse cartridge into the fitting screw of a 25 amp fuse cartridge.

The fuse cartridges has ceramic body of the cartridge with its foot and head contacts. The two contacts are linked by a fuse wire which is embedded in sand. Each cartridge has a break indicator which will be ejected from the cartridge if the fuse wire is burnt out (Fig 6).

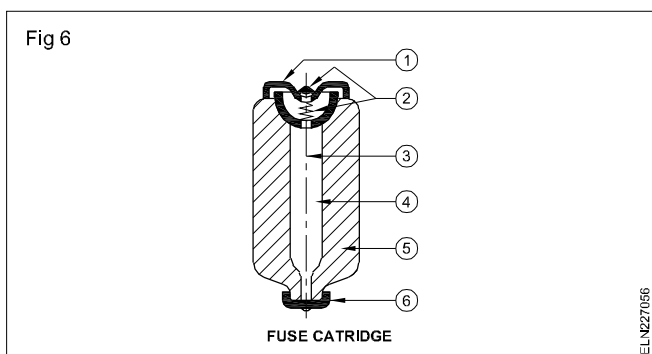

The parts of this fuse cartridge are

- head contact (1)
- break indicator (2)
- fuse wire (3)
- sand filling(4)
- ceramic fuse body (5)
- foot contact (6).

For easy identification of the fuse cartridges and the corresponding fitting screws, they are marked with various colours at the places (Fig 7). For each current rating, a different colour is used.

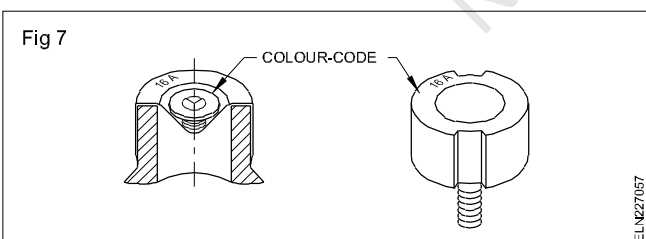

Pink	- 2 amperes	Blue	- 20 amperes
Brown	- 4 amperes	Yellow	- 25 amperes
Green	- 6 amperes	Black	- 32 amperes
Red	- 10 amperes	White	- 50 amperes
Grey	- 16 amperes	Copper	- 63 amperes

The flow of the electric current through the fuse base and the fuse is as shown in Fig 8. In order to prevent the accidental touching of a live line, the electrical supply must be connected to the terminal which is connected to the fixing screw at the bottom of the base.

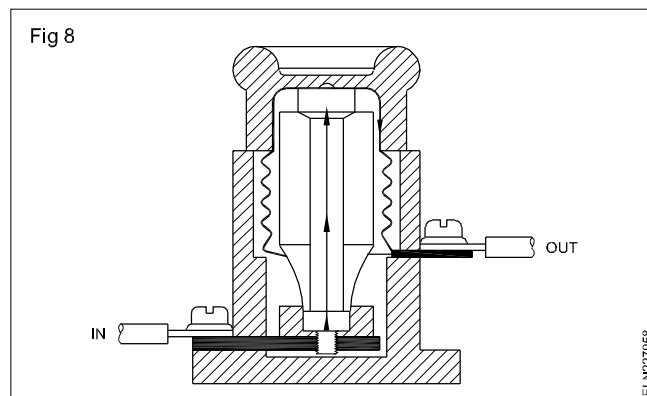

Diazed type fuses are available in two categories, a) quick-response type and b) delayed-action type. The quick-response type is used for heating circuits and normal loads whereas the delayed-action type is used for motor circuits and highly inductive circuits.

High rupturing capacity (HRC) fuses (Fig 9): They are cylindrical in shape and are made of a ceramic body filled in with a chemically treated filling powder or silica to quench the arcing quickly without any fire hazard.

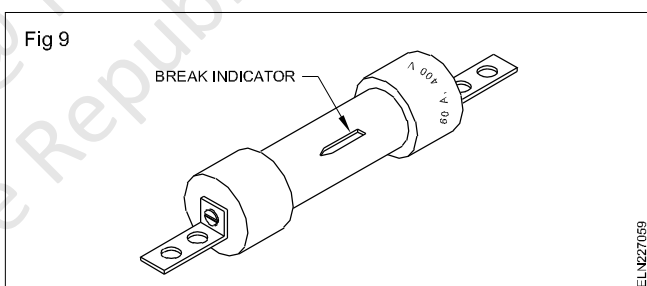

Normally a silver alloy is used as the fusing element and when it melts due to the excessive current, it combines with the surrounded sand/powder, and forms small globules without making an arc, spark or gas. HRC fuses can open a short-circuited circuit within 0.013 second. It has an indicator to show the fuse has blown. The rupturing capacity of the fuse could be calculated from the following formula.

$$\text{Rupturing capacity in MVA} = \frac{\text{Fault current in amperes} \times \text{Circuit voltage}}{10^6}$$

As HRC fuses are capable of opening circuits having very high faulty currents, these are preferred in high power circuits even though the replacement cost is high.

Comparison between HRC & Rewirable fuses

Factor	Rewirable	HRC fuse
Rupturing capacity	Not recommended for currents exceeding 200 A or for more than 600V or where there is a possibility of S.C. fault of more than 5 MVA.	Normal types cater to fault loads up to 2500 KVA. For certain applications, fuses up to 50 MVA are obtainable.
Rupturing speed (Cut-off factor)	Rating and cut-off are not absolutely reliable.	Very rapid. Usually AC supply current is cut off within the first half cycle.
Discrimination	Poor.	Accurate.

Factor	Rewirable	HRC fuse
Safety in operation	Risk of flash-over under heavy fault condition.	No external flame.
Deterioration	Oxidation and consequent scaling causes reduction in the cross-sectional area, thus increasing resistance, and leading to overheating and premature rupturing.	No oxidation. The element is completely sealed.
Fusing factor	Copper wire upto 20A - 1.7. Over 20A - 2.0.	As low as 1.1.

Relays - types - symbols

Objectives: At the end of this lesson you shall be able to

- define a relay and classify the relays
- classify relays according to the operating force and function
- state the common codes used for specifying contacts and poles
- specify a relay
- explain the function of the shading coil in an AC relay
- state the causes of the failure of the relay
- identify the symbols used in relay as per I.S.2032 (Part XXVII).

Relay: A relay is a device which opens or closes an auxiliary circuit under predetermined conditions in the main circuit.

Relays are extensively used in electronics, electrical engineering and many other fields.

There are relays that are sensitive to conditions of voltage, current, temperature, frequency or some combination of these conditions.

Relays are also classified according to their main operating force as stated under.

- Electromagnetic relays
- Thermal relays

Electromagnetic relay: A relay switch assembly is a combination of movable and fixed low-resistance contacts that open or close a circuit. The fixed contacts are mounted on springs or brackets, which have some flexibility. The movable contacts are mounted on a spring or a hinged arm that is moved by the electromagnet in the relay (Fig 1).

The other types of relays coming under this group are as follows.

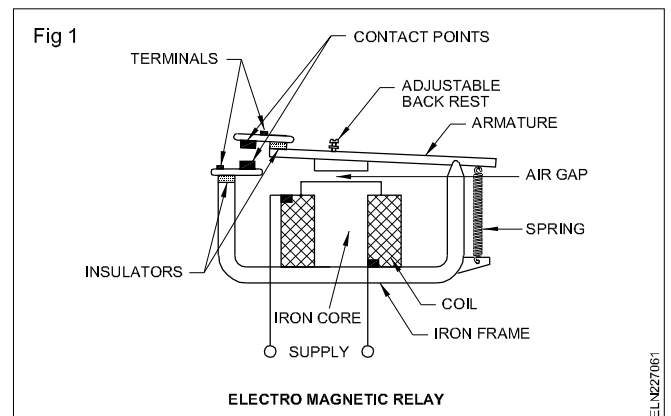

Current sensing relay: A current sensing relay functions whenever the current in the coil reaches an upper limit. The difference between the current specified for pick up (must operate) and non-pick up (must not operate) is usually closely controlled. The difference in current may also be closely controlled for drop out (must release) and non-drop out (must not release).

Under-current relay: Under-current relay is an alarm or protective relay. It is specifically designed to operate when the current falls below a predetermined value.

Voltage sensing relay: A voltage sensing relay is used where a condition of under-voltage or over-voltage may cause a damage to the equipment. For example, these types of relays are used in voltage stabilizers. Either a proportional AC voltage derived from a transformer or a proportional DC derived from a transformer and rectifier used for this purpose.

Latching relays

Latching relays are capable of maintaining their contacts in the last assumed position without the maintained current in the coil. These relays hold their contacts in position after power is cut off.

There are two basic kinds of latching relays called mechanical reset and electrical reset.

Mechanical re-set relays: Mechanical re-set relays have a coil, an armature mechanism, and a mechanical latching device that locks the armature in the operated position after the coil has been de-energised. Manual tripping of the locking mechanism, re-sets the relay.

Electrical reset relays: An electrical re-set relay (Fig 2) has the same operating mechanism, but it includes a second coil and armature to trip the latching mechanism. This system allows remote re-setting of the relays to their original position.

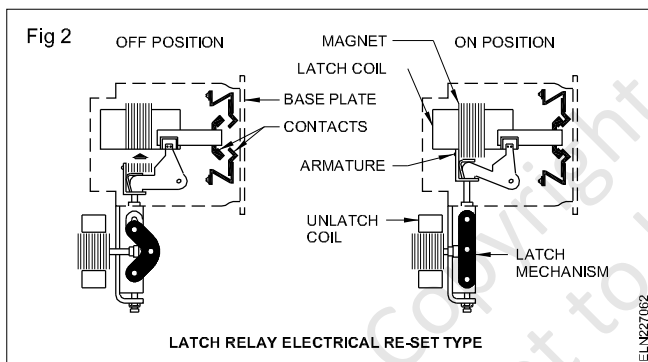

Reed relays

Reed relays physically look different than other kinds of relays. They consist of essentially magnetically actuated reed switches, with actuating solenoids or coils.

In the reed relay, freedom from contamination and the limited number of moving parts, avoid many disadvantages of the conventional electromechanical relays. In addition to the above, the contact resistance is kept to minimum due to the fact the contact points are made either with gold or rhodium. Further, these relays need very low power to operate and can handle a 250 watt solenoid load on their contacts.

There are three types of reed relays namely

- dry-reed relay
- ferreed relay
- mercury wetted contact relay

Dry reed relay: Two opposing reeds are sealed in to a narrow glass tube (Fig 3). The reeds overlap at their free ends. At the contact area, they are usually plated with gold or rhodium to produce a low contact resistance. They may have multipole multicontact designs.

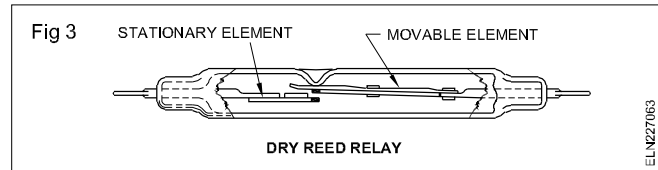

Ferreed relay: The word ferreed denotes a reed relay in which the dry-reed switch is contained with one or more magnetic members. The magnetisation can be changed by current pulses in associated coils.

In the magnetised state the magnetic members supply a field strong enough to close the contacts. In the other magnetised state, the field is too weak to hold the contacts closed (Fig 4). An operating pulse through the coil produces the first state. A release pulse produces the second state. The contacts can break or make within 5 micro-seconds duration.

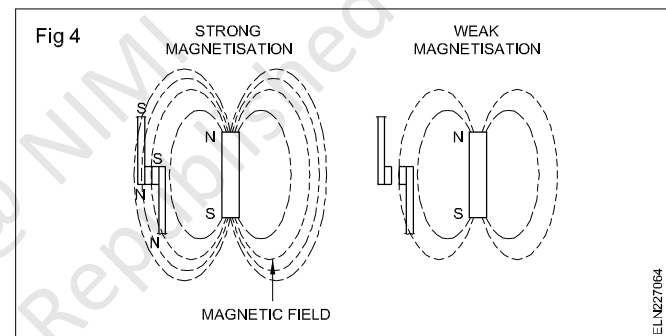

Mercury wetted contact relay: This relay consists of a glass enclosed reed with its base immersed in a pool of mercury (Fig 5). When the coil surrounding the capsule is activated, mercury makes the contact between fixed and movable contacts.

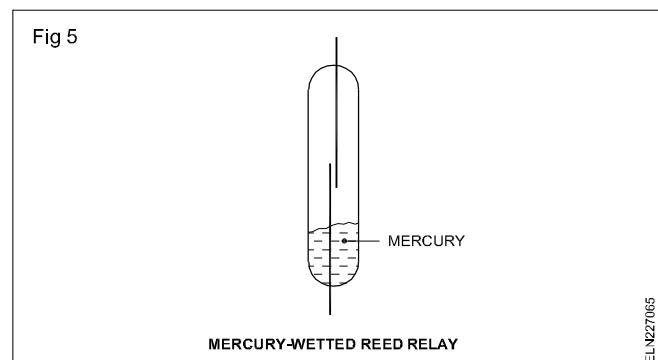

Impulse relay: The impulse relay (Fig 6) is a special single-coil relay. It has an armature-driven mechanism that alternatively assumes one of two positions as the coil is pulsed. This mechanism moves the contact from one position to the other and back again as electrical pulses are received. The relay can operate on AC or DC power.

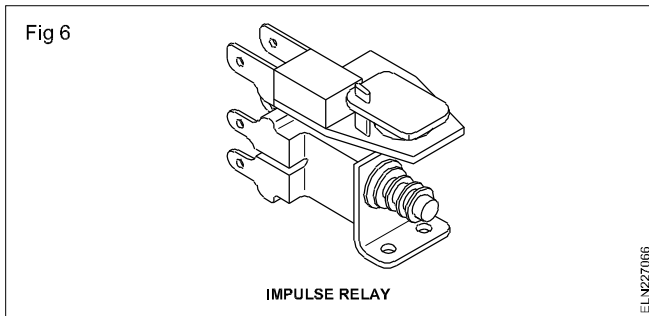

Clapper-type armature relay: The simplest contact arrangement used in armature relays is the break-make or transfer-contact combination. A clapper-type armature, (Fig 7) opens or closes the contacts. A movable contact is attached directly to the armature by means of a flexible strip of metal. When the electromagnet operates, the armature moves this contact, opening and closing the two sets of contacts.

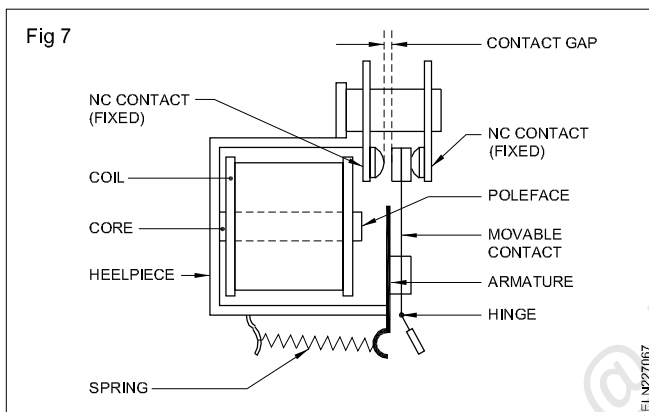

Thermal relay: A thermal relay (Fig 8) is one that operates by changes in temperature. Most of the bimetallic relays where the bimetallic element changes its shape, in response to changes in temperature comes under this group.

It takes time for the heating element to reach the necessary temperature and more time to raise the temperature of the bimetallic element. Therefore, thermal relays are often used as time-delay relays.

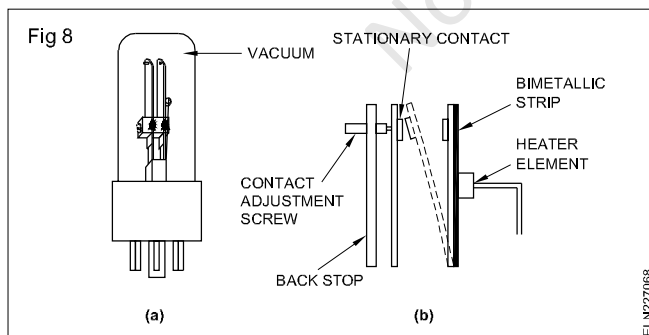

Poles and contacts: Relays may operate single or as multi-poles and may open or close specified contacts. In writing specifications certain abbreviations as stated below are commonly used.

- SP - Single pole
- SB - Single break
- ST - Single throw

- DB - Double break
- DP - Double pole
- DM - Double make
- DT - Double throw
- NO - Normally open
- 3P - Three pole
- NC - Normally closed

4P - Four pole

For example a 4PDT has a four-pole, double throw contact arrangement.

NO indicates the contacts are open in the unoperated position of the relay and they are called as normally open (NO) contacts.

NC indicates the contacts are closed in the unoperated position of the relay and they are called normally closed (NC) contacts.

Enclosures and mounts: Relays are normally enclosed in plastic or metal caps to protect the operating parts against dust and environment. Relays can be mounted to the circuit direct by plug-in system, PCB mounting or may be wired separately using screws terminals (Fig 9).

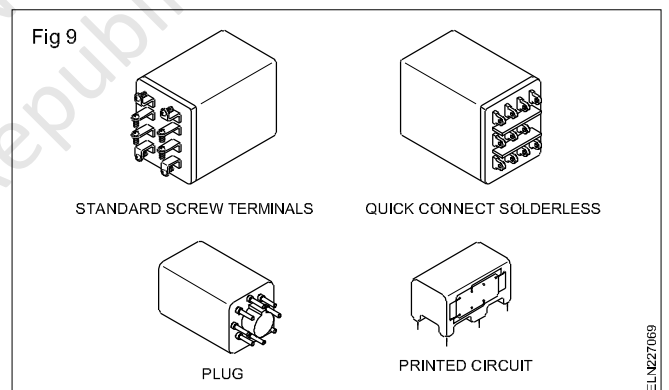

AC relay: In an AC relay magnet, the magnetic field continually changes direction. With a 50 Hz supply the magnetic field passes through zero 100 times per second. At the time of zero field, the armature starts to release. Although the field quickly builds up in the reverse direction, a noisy chatter can result.

To eliminate chatter, a shading coil (Fig 10) is placed near the tip of the magnet pole face. This shading coil establishes a magnetic field that lags the main magnetic field slightly and aids in keeping the magnet sealed when the main field passes through zero.

An AC relay should not be used in DC supply.

The AC relay when connected to DC supply, will draw more current in the absence of inductive reactance and result in burning out the coil.

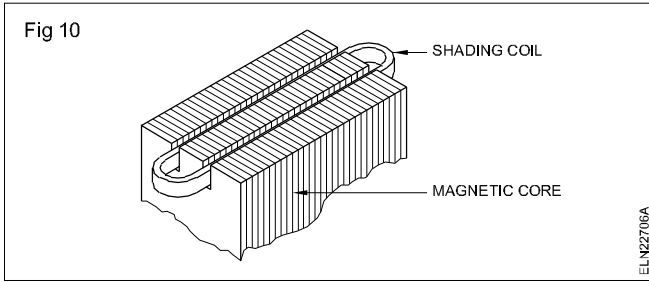

Causes of relay failures: Relay failures are usually caused by the gradual deterioration of the parts. This deterioration can be electrical, mechanical or chemical in nature.

The environmental shirks that contribute to physical break-down include large temperature changes, shock, vibration and voltage or current changes. Therefore, it is important that these factors are taken into consideration to ensure reliable performance of relays.

In general, when a relay fails, look for the following.

- 1 Improper control voltage.
- 2 Dirt, grease or gum on contacts or moving parts.
- 3 Excessive heating of parts: discolouration or charred insulation on coil or base.
- 4 Bending of moving parts.

- 5 Corrosion or deposits on metal parts.
- 6 Excessive wear on moving parts.
- 7 Loose connections.
- 8 Improper spring tension.
- 9 Improper control pressure.
- 10 Improper functioning of the time delay device.

While specifying relays the following particulars are necessary.

Type of operating voltage

AC or DC

Sequence of operation _____

Operating voltage _____ volts

Current rating _____ amps

Coil resistance _____ ohms

Number of contacts _____ NO _____ NC

Number of poles _____

Type of mount _____

Type of enclosure _____

Table 1 given below lists some of the relay contact combinations.

Table 1

Design	Sequence	Symbol
1 SPST-NO	Make 1	
2 SPST-NC	Break 1	
3 SPDT	Break 1 before make 2	
4 SPDT	Make 1 before break 2	
5 SPDT (B-M-B)	Break 1 before make 2 before break 3	
6 SPDT-NO	Center OFF	
7 SPDT-NC-NO (DB-DM)	Double break 1 double make 2	
8 SPST-NO (DM)	Double make 1	
9 SPST-NC (DB)	Double break 1	
10 SPDT-NC (DB-DM)	Double break 1 double make 2	

NE code Mounting accessories - specification of wooden boards and blocks

Objectives: At the end of this lesson you shall be able to

- state the National Electrical Code of Practice with respect to mounting accessories and boards
- specify the wooden round blocks and boards for mounting electrical accessories.

Recommendations of the National Electrical Code for mounting the accessories on the boards

When electrical accessories are to be mounted on the boards, the following National Electrical Code recommendations should be adopted.

- All ceiling roses, brackets, pendants and accessories shall be mounted on substantial wooden blocks, having a depth of not less than 4 cm.
- Where teak or hardwood boards are used for mounting switches, regulators etc., these boards shall be well varnished with pure shellac on all sides (both inside and outside), irrespective of being painted, to match the surroundings. The size of such boards shall depend on the number of accessories that could be conveniently and neatly arranged.
- No mounting of accessories shall be done within 2.5 cm of any edge of the panel of the board, and no hole other than the holes by means of which the panel is fixed shall be drilled closer than 1.3 cm from any edge of the panel.
- A switchboard shall not be installed with its bottom within 1.25 m above the floor unless the switchboard is enclosed in a box with locking arrangement.
- If the switchboards are recessed in the wall, the front shall be fitted with a hinged panel of teakwood or other suitable material, such as bakelite, or fitted with an unbreakable glass door in teakwood frame.
- Open type switchboards shall not be placed in the vicinity of storage batteries or exposed to chemical fumes.
- Switchboards shall not be erected above gas stoves or sinks, or within 2.5 m of any washing unit in the washing room.
- Unnecessary crossing of connections should be avoided between apparatus and terminals, within the board.
- In a hinged type board, the incoming and outgoing cables shall be fixed at one or more points according to the number of cables on the back of the board, leaving suitable space in between the cables, which shall also, if possible, be fixed at the corresponding points on the switchboard panel. The cables between these points shall be of such length as to allow the switchboard panel to swing through an angle of not less than 90°.

Specification of commercially available boards, round blocks for mounting electrical accessories

The boards which are used for wiring installation are available in different sizes, made up of teak wood, P.V.C. or metal. When selecting the boards, the following points are to be considered.

Size of the board: The number and type of accessories to be mounted on the board decide the size of the board. After selecting the accessories to be mounted on the board, the layout may be formed on a cardboard template, and then the size of the board may be determined.

System of wiring: This decides whether boards should be placed on the surface of the wall or flush-mounted. Accordingly, a single or hinged board could be selected. However, depending upon the system like batten or metal conduit or PVC conduit, the board may be made of wood, metal or PVC respectively.

Place of wiring : This is another deciding factor to choose the material of the board. For indoors we may use board of any material depending upon the system of wiring.

Specification for blocks and boards

While specifying the boards for wiring installation, the following particulars shall be given.

- Material of the board - wood, PVC or metal.
- Size - length, breadth and height in mm.
- Thickness of the material in mm.
- Single or double (double-hinged or non-hinged type).
- Additional information like type of finish on wooden boards, colour of PVC or metal boards, surface or flush mounting etc.

T.W. round blocks: For specifying the round blocks, its overall diameter and thickness have to be given. Single and double (with base block) round blocks are available. Nowadays, P.V.C. blocks are also in use. The following sizes are available commercially. The first dimension denotes the overall diameter, and the second dimension denotes the thickness of the block.

Round blocks - single	Round blocks - double
75 mm x 25 mm	75 mm x 35 mm
75 mm x 40 mm	75 mm x 40 mm
90 mm x 25 mm	90 mm x 35 mm
90 mm x 40 mm	100 mm x 35 mm
100 mm x 25 mm	100 mm x 40 mm
100 mm x 40 mm	

Instead of round blocks, square blocks are also available. For certain special purposes hexagonal shape blocks are also used. According to the code of practice, the minimum thickness of round blocks should be 40 mm.

T.W. boards

For fixing two or more accessories on one board or for fixing accessories like fan regulators, D.P. switches etc. T.W. boards are used. Generally, the following sizes of boards are available commercially, in teak wood, PVC or metal.

The minimum thickness of non-hinged boards should be 40 mm whereas for hinged boards the thickness varies from 65 to 80 mm.

Specification: Metric System

Length	Breadth	Length	Breadth
100 mm	100 mm	300 mm	250 mm
150 mm	100 mm	380 mm	450 mm
150 mm	150 mm	450 mm	250 mm
200 mm	150 mm	450 mm	300 mm
200 mm	200 mm	600 mm	300 mm
250 mm	200 mm	600 mm	300 mm
300 mm	200 mm	750 mm	600 mm

Through and pilot holes - wood-machine screw specifications

Objectives: At the end of this lesson you shall be able to

- determine the size of through holes, with respect to the cable size and the number of cables
- state the method of making pilot holes using a bradawl or gimlet or by undersized drills
- specify wood screws and machine screws.

Determining the through hole size according to the cable size and number of cables

While drilling holes in the boards for cable entry, the overall diameter of the cable has to be known. The overall dia. of the cable may vary according to the type of insulation used, and also from one manufacturer to another. Further the size depends upon the voltage grading. Hence the best practice is to take a piece of the cable, measure the overall size and select a suitable drill so that the cable enters the hole freely. When the number of cables to be inserted is more than one, the drill size may be selected accordingly.

The overall dia. and the overall sizes of the cables are indicated in Table 1.

TABLE 1
Sizes of conductors

Conductor of cables		Approximate overall dia. of cables	
Normal area in mm ²	Number and dia of wire in mm	250V grade in mm	660 V grade in mm
1.5	1/1.40	4.20	5.40
2.5	1/1.80	4.60	6.00
4.0	1/2.24	5.25	6.80
6.0	1/2.24	6.00	7.35
10.0	1/3.55	7.10	8.10
16.0	7/1.70	8.85	9.65
25.0	7/2.24	10.80	11.50
35.0	7/2.50	11.75	12.25
50.0	7/3.00	13.40	13.90
70.0	19/2.24	---	16.70
95.0	19/2.50	---	19.10

Example: Referring to Table 1 it is found that for a 2.5 sq.mm. size conductor of the cable, the diameter of the cable (including insulation) is 4.6 mm. Hence, the hole size can be determined as 5 mm dia. and the drill required is of 5 mm dia.

The method of making pilot holes in wood using bradawl and gimlet

Pilot holes should always be made in the wood, when using wood screw for fixings so that the screw can be driven securely into the wood without damaging the wood, and is fixed with less effort.

First, position the accessories to be fitted on the board according to the layout and also to meet the aesthetic requirements. Open the cover and identify the places where the pilot holes are to be made. The usual practice is to identify the cable entry 'through holes' and the screw fixing 'pilot holes' with different distinct markings.

Use a bradawl for making the pilot holes in softwood. If a gimlet is chosen, it should not be bigger than the wood screw proposed to be fitted. Pilot holes can be made in softwoods for screws up to size 6. For larger sized screws and for harder woods, pilot holes can be made best by a gimlet, or a second choice is by drilling undersized holes.

Select the correct size of drill for pilot holes: Drill sizes should be about 2 mm smaller in diameter than the diameter of the screw shank.

Drill hole to correct depth: In softwoods - hole depth equals 1/2 screw length.

In hardwoods - hole depth equals screw length.

For secure fixings it is important not to drill holes too deep.

Wood screws: These screws have a single spiral of thread running from the point, clockwise for about two thirds of the length. The unthreaded part is called the shank, and gives the 'screw number' (Designation number).

Types of wood screws

Wood screws are classified with respect to the shape of the heads. Accordingly 3 types of wood screws are used for wiring installation.

Slotted countersunk head wood screws (Fig 1): This type of screws is used for general wood work for fitting miscellaneous hardware.

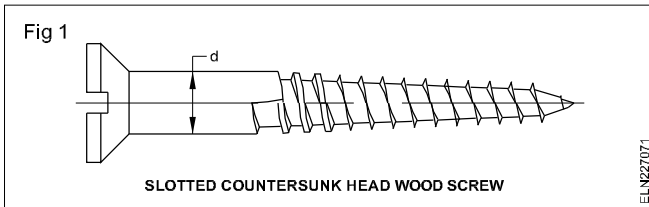

In electrical wiring for fixing wooden blocks, boards, battens and electrical accessories, countersunk holes should be used. The screw shall be driven until the head is flush with the work or slightly below surface.

Slotted round head wood screws (Fig 2): This type of wood screws is used for surface work, for installing electrical fittings and accessories where fitting holes are not countersunk.

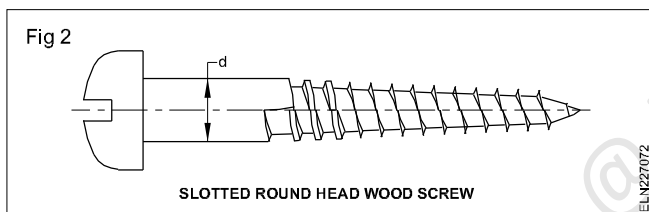

Slotted raised countersunk head wood screws (Fig 3): Raised countersunk wood screws are used for fixing decorative electrical fittings. Even for fixing flush type electrical accessories on T.W. board or box, raised countersunk wood screws are used.

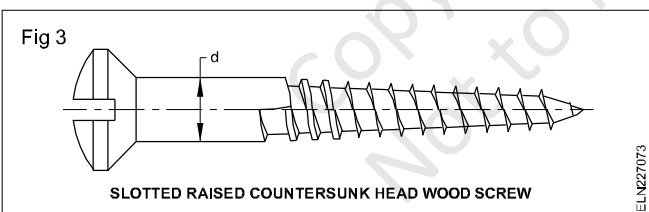

Of the three types of screws listed above, countersunk (flat head) screws are commonly used for electrical wiring installations.

Designation of wood screws: Wood screws shall be designated by the screw number, length, type of head and material. Table 2 gives the designation number, shank diameter available and length for slotted countersunk wood screws.

Example 1: A slotted countersunk head wood screw of shank 4.17 mm dia. length 20 mm, made of steel shall be designated as

Wood screw No. 8 x 20 countersunk steel (or)

Wood screw No. 8 x 20 I.S. 6760 steel.

The preferred length and screw number of countersunk wood screws are given in Table 2.

Example 2: A slotted round head wood screw of shank, 3.45 mm dia. length 30 mm, made of steel shall be designated as

Wood screw No.6 x 30 round head steel or
Wood screw No.6 x 30 I.S. 6739 steel.

Example 3: A slotted raised countersunk head wood screw of 2.08 mm dia. length 12 mm, made of steel shall be designated as

Wood screw No.2 x 12 raised countersunk steel, or
Wood screw No.2 x 12 I.S. 6736 steel.

Selection of the correct type, size and length of screws: Note the surface finish on the fixture at the fixing point, where a recess is provided. Select a countersunk screw; if not, select a round head screw.

Check the size of the hole in the fixture, then select a screw with a screw shank diameter equal to the hole size.

Decide on the length of the screw from the thickness of the fixture, and the thickness of the wood that the fixture is to be fixed in.

Screwing methods

In softwood: Locate the fixture and screw over the hole and tighten the screw.

In hardwood: Locate the screw in the hole and drive the screw for atleast 5 turns. Withdraw the screw, then locate the fixture and screw over the hole and tighten the screw. When the fixture has more than one fixing hole prepare the uppermost hole, and allow the fixture to hang from its fixing screw while the other fixing screws are located and then tightened.

Precautions to be adopted while fixing wood screws

- Before fixing the wood screws, the tip of the screws must be coated with rust-preventing material such as soap, wax etc.

Screws should never be hammered.

- Use a proper screwdriver which fits as closely as possible in the slots of the screws.
- Do not use a high-leverage screwdriver for fixing small screws.
- Pilot holes should be made, before fixing the wood screws.

Advantages of screws over nails

Screws provide for a more secure fixing than is possible with nails, and have the further advantage that they may be loosened or tightened as required. Screws can be made from rust-proof and corrosion-resistant materials, like brass, stainless steel, aluminium alloy, bronze etc.

Machine screws: Machine screws are used for securing component and assembly work.

These screws should normally be screwed into tapped holes or used with nuts.

Types of machine screw head

Machine screws are mainly classified with respect to the shape of heads. The different types of screw heads in general use is given below (Fig 4).

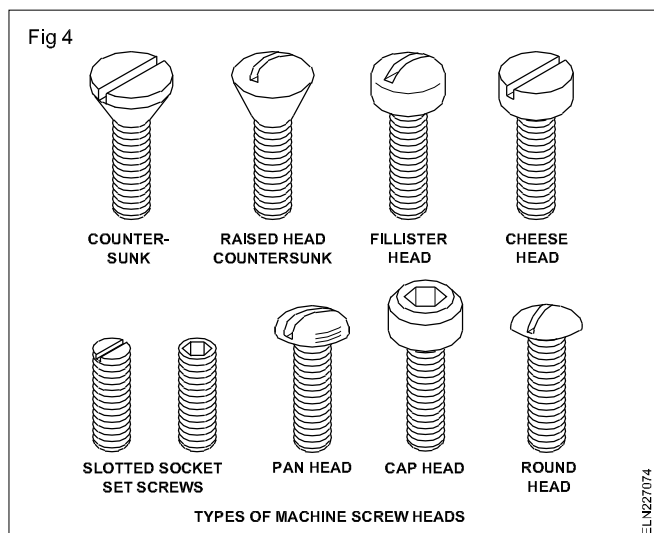

Application: The cheese head type of screws is used for general assembly work.

Flush fitting screws are used when there is little clearance between assemblies or where protruding heads are not desirable.

The semi-flush type is used mainly for panel assembly or where a pleasing appearance is required.

Types of threads

Various types of thread screws are available.

Metric threaded screws: These screws are normally specified with alphabet 'M'. M4, where '4' denotes the diameter of the screw in mm, and M denotes the type of thread in metric. Hence 'M4 x 20' is a machine screw of metric thread having 4 mm dia. and 20 mm length.

BA (British Association) threaded screws: These screws are specified with the letters 'BA'.

Unified national threaded screws (UNF): These screws are specified as 'UNF' i.e. 'Unified National Fine' or 'UNC' i.e. 'Unified National Coarse'.

Self-tapping screws: These are also called 'Thread forming tapping screws'. They are specified in screw size and number, similar to the wood screws.

Specification: While specifying a machine screw, it is essential to mention the head type, screw length and the thread type.

Table 2

Screw No.	Nominal diameter of un-threaded shank in mm.	Preferred length in mm															
		8	10	12	15	20	25	30	35	40	45	50	55	60	65	70	75
0	1.52	✓	✓	✓													
1	1.78	✓	✓	✓													
2	2.08	✓	✓	✓													
3	2.39	✓	✓	✓													
4	2.74			✓	✓	✓	✓										
5	3.10			✓	✓	✓	✓	✓									
6	3.45			✓	✓	✓	✓	✓	✓								
7	3.81			✓	✓	✓	✓	✓	✓	✓							
8	4.17			✓	✓	✓	✓	✓	✓	✓	✓	✓	✓	✓	✓	✓	✓
9	4.52				✓	✓	✓	✓	✓	✓	✓	✓	✓	✓	✓	✓	✓
10	4.88				✓	✓	✓	✓	✓	✓	✓	✓	✓	✓	✓	✓	✓

Types of wiring : Domestic and Industrial - selection of cable size

Objectives: At the end of this lesson you shall be able to

- state the types wiring used in domestic installations
- state the use of cord grip and underwriter's knot.

Introduction

The type of wiring to be adopted is dependent on various factors viz. location durability, safety, appearance, cost and consumer's budget etc.

Types of wiring

The following are the types of internal wiring used in domestic installations.

- Cleat wiring (for temporary wiring only)
- CTS/TRS (batten) wiring
- Metal/PVC conduit wiring, either on surface or concealed in the wall.
- PVC casing & capping wiring

Cleat wiring

This system uses insulated cables supported in porcelain cleats (Fig 1).

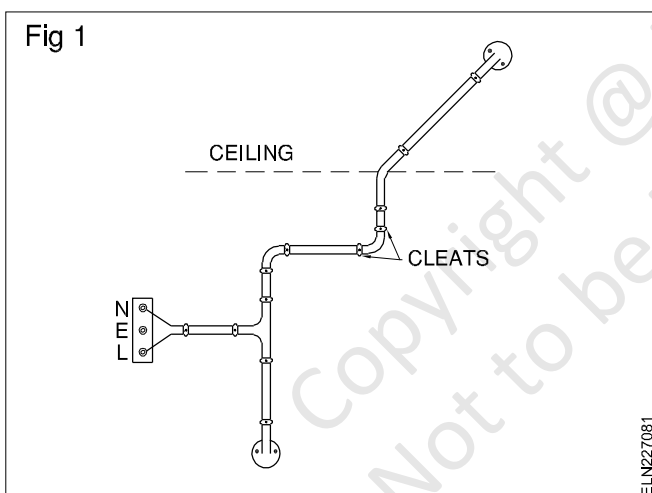

Cleat wiring is recommended only for temporary installations. These cleats are made in pairs having bottom and top halves (Fig 2). Bottom half is grooved to receive the wire and the top half is for cable grip.

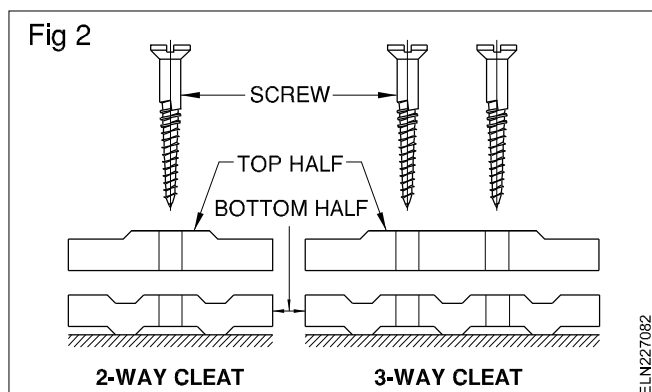

Initially the bottom and top cleats are fixed on the wall loosely according to the layout. Then the cable is drawn through the cleat grooves, and it is tensioned by pulling and the cleats are tightened by the screw.

The cleats are of three types, having one, two or three grooves, so as to receive one, two or three wires.

Cleat wiring is one of the cheapest wirings considering the initial cost and labour, and is most suitable for temporary wiring. This wiring can be quickly installed, easily inspected and altered. When not required this wiring could be dismantled without damage to the cables, cleats and accessories. This type of wiring may be done by semi-skilled persons.

Cord grip and underwriter's knot

When a lamp or lamp with its shade is hung from the ceiling, the flexible cable connected to the lamp-holder is subjected to mechanical stress due to the weight of the lamp-shade and the lamp.

If the stress is not removed, the cable connection may come out of the terminals and result in shock hazards. To relieve the strain from the terminals of pendants, lamp-holders and ceiling roses, a cord grip or an underwriter's knot is used. A cord grip or underwriter's knot is also used in pull switches and other portable appliance connectors.

Underwriter's knot (Fig 3)

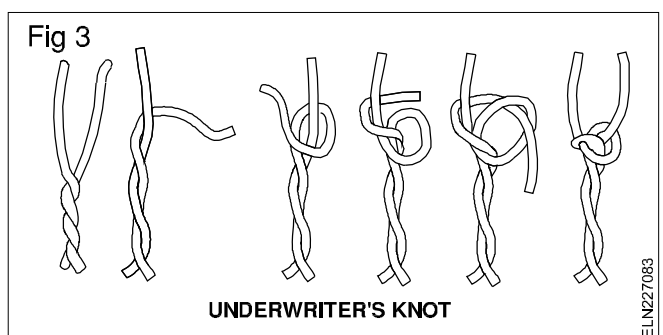

A knot is made on twin-twisted or twin-core flexible cable inside the accessories' cap cover.

Cord grip (Fig 4)

In some of the electrical accessories like lamp-holders, appliance connectors, plug pin tops etc. a cord grip arrangement is provided. These are an effective means of relieving the terminals from strain due to pulling or twisting of the cord.

Fig 4

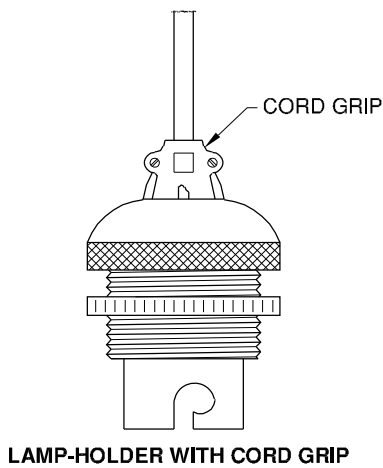

ELN227084

Types of electrical wiring

Objectives: At the end of this lesson you shall be able to

- explain the types of electrical wiring and their application
- state the advantages and disadvantages of each types.

Many wiring systems are developed to meet the safety requirements, economy of cost, easy maintenance and trouble shooting. A particular system can be chosen according to technical requirements but the system needs to be approved by the local electricity authorities. The following are the fundamental requirements for any wiring system. They are:

- For safety, switches should control the live phase wire. The second terminal of the switch called as half wire should be connected to the appliance or socket through the wire. The neutral can be connected directly to the appliance, socket or lamp. This enables the workman to rectify the defects of the particular lamp or appliance by switching off the particular circuit only and the main supply need not be switched 'off'.
- For safety, fuses should be placed in the live/phase wire only. The lamp should not get supply when the fuse is blown.
- To supply the rated voltage, parallel connections should be given to all lamps and appliances.

Types of wiring system: There are three types of wiring systems used for tapping supply from mains to the different branches. They are as follows.

- 1 Tree system
- 2 Ring main system
- 3 Distribution board system

Tree system: In this system, copper or aluminium strips in the form of bus bars are used to connect the main supply to the raising mains (Fig1). This system is suitable for multi-story buildings and the bus bar trunking space is provided in the building at a convenient location and at load centres for the purpose of economy.

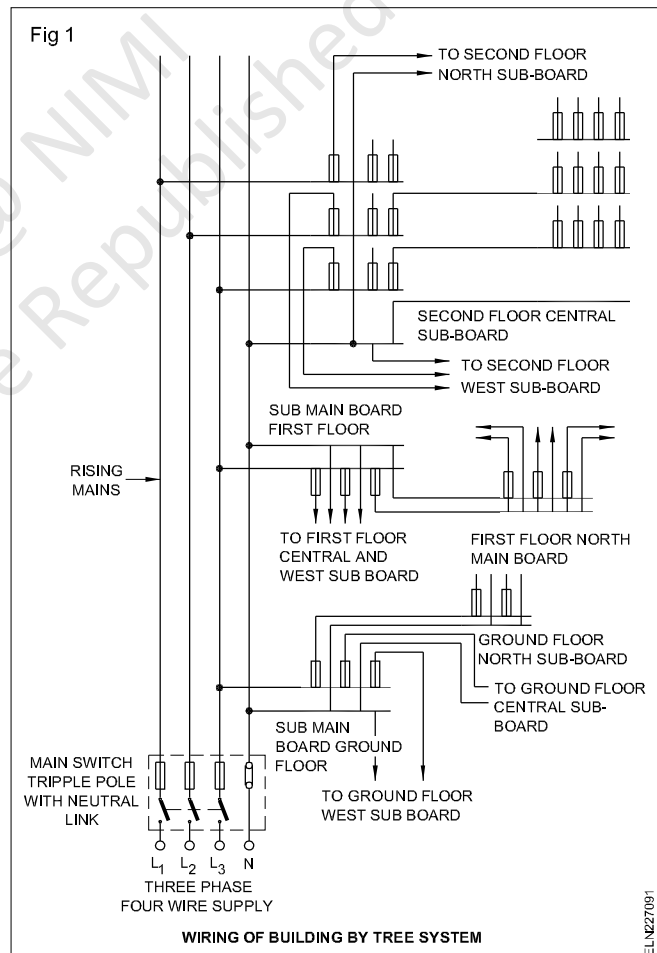

ELN227091

At each floor the running main is connected to the sub-main board through proper cable terminations. If there are more than one flat in each floor the individual main switches for the flat get their supply from the sub-main board through a distribution network which may include an energy meter for each flat.

However the system adopted within the flat will be the distribution board system.

Advantages

- 1 The length of the cables required for installation will become less. Hence, the cost is less.
- 2 This system is suitable for high rise buildings.

Disadvantages

- 1 The voltage across the appliances which are at the farthest end of the tree system may be less when compared to the one connected to the nearest end if the bus bars size is not of sufficient size.
- 2 As fuses are located at different places, fault location becomes troublesome.
- 3 When aluminium bus bars are used for economic considerations, the tappings can become loose and interrupt power supply.

Ring main system: This system consists of two pairs of cables of size 4 or 6sq.mm which run through the rooms and are brought back to the main or sub-board (Fig 2 and 3). Tappings are taken for sockets or ceiling roses from the pair of cables through fuses and controlling switches. There may be saving of copper used because the current can be fed from both sides. As this system requires special sockets or plugs with fuses it becomes costly; and hence rarely used in India.

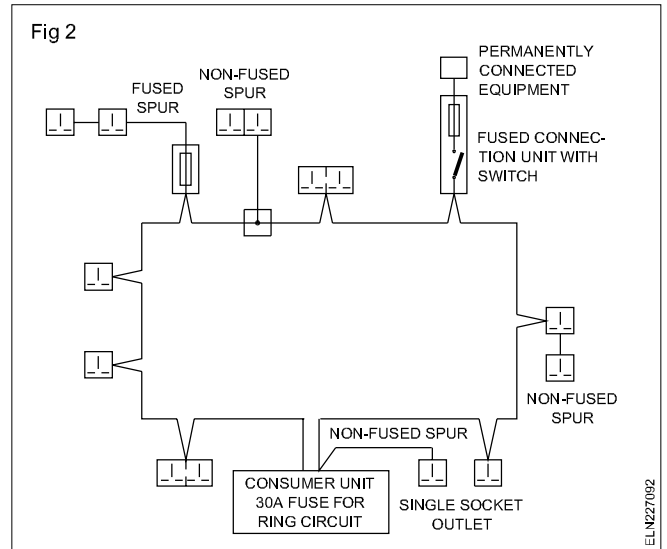

As per IEE regulations one ring circuit has to be there for every 100 sq metres of the floor area or part thereof. The number of power plugs fed from branch lines (spurs) should not exceed two and the total current should not exceed 30 amps. Protection for individual power plug can be provided by having built-in-fuses with the individual power plugs or by having MCB type switch and socket arrangement.

Distribution board system: This is the most commonly used system. This system enables the appliances connected to the system to have the same voltage. The main switch is connected to the distribution board through

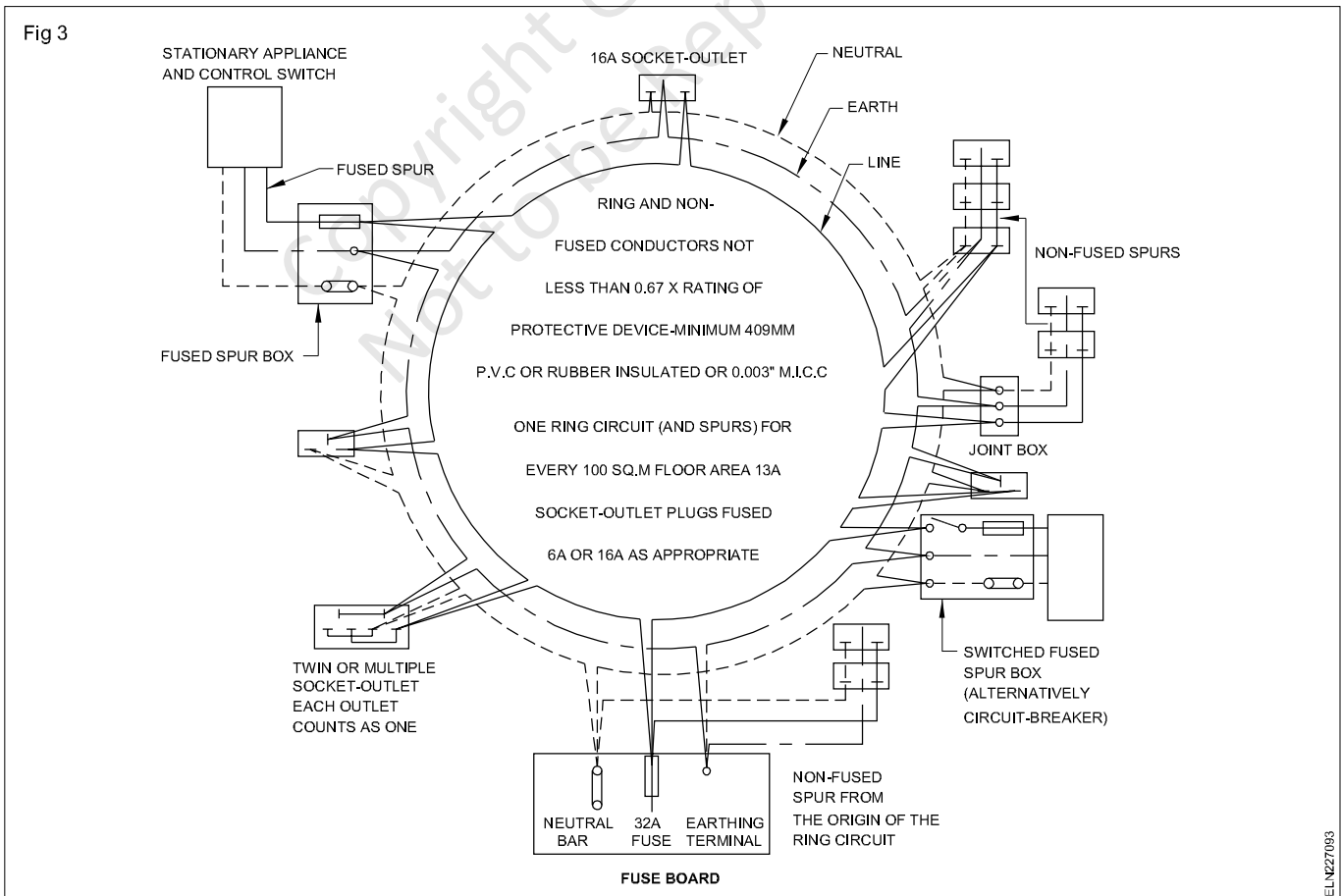

suitable cables. The distribution board has a number of fuses depending upon the number of circuits required in the installation, and the phase and neutral cable of each phase are taken from the distribution board (Fig 4).

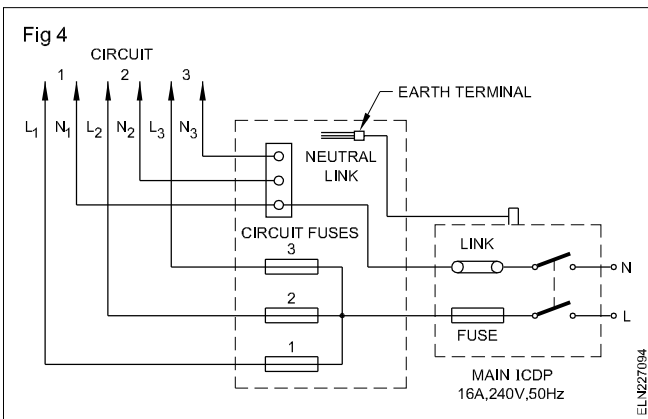

As each circuit can have power up to 800 watt, the phase wire which is taken from the circuit fuse of the distribution board is looped to the other light switches or fan switches of the same circuit by any one of the following ways.

No joint is allowed in the cable route except in switches, ceiling roses and joint boxes.

a Looping out from switch and ceiling rose: Fig 5 shows the simple looping in method which is commonly employed. The phase wire which is connected to the terminals of the switch is looped out to the next switch and so on, whereas the neutral wires are looped together from ceiling roses (Fig 5). Cable consumed in this system is very high.

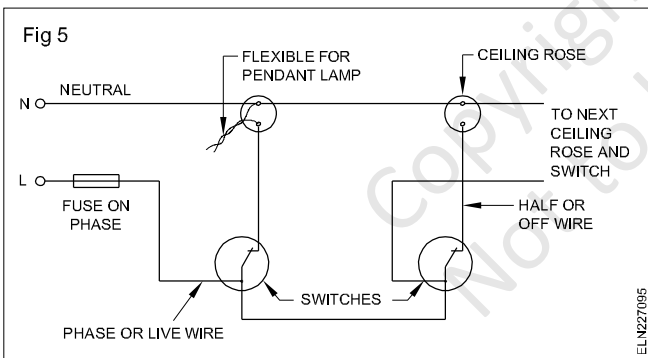

b Looping out from switch: This system employs special switches having two terminals and one connector (Fig 6). Both the phase and neutral cables are taken to the switch for looping the cables. As these accessories are not commonly manufactured in India such a system is not used.

c Looping out from 3-plate Ceiling roses: In this type of system, three terminal ceiling roses need to be used (Fig 7). As this system uses less cables when compared to (a), this system is in use in some parts of India.

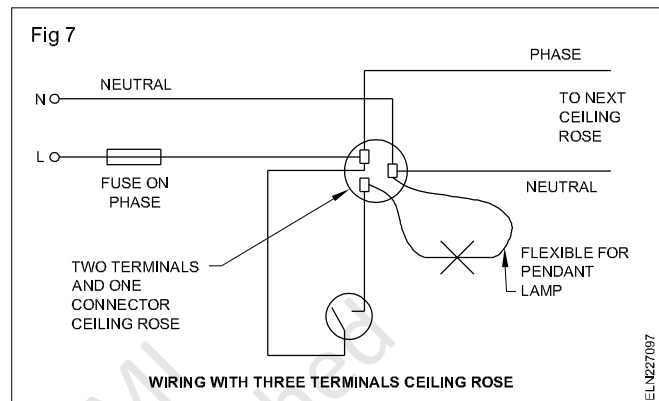
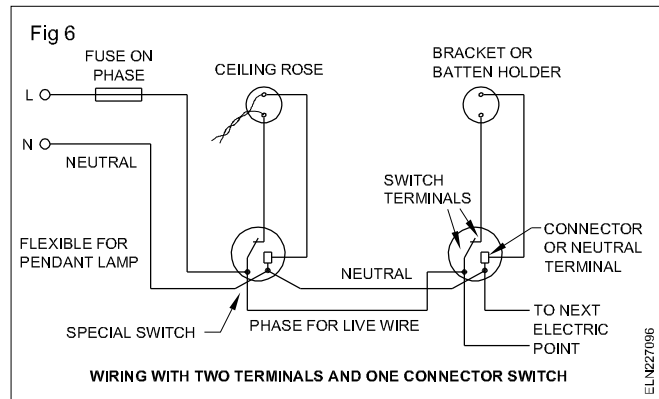

d Looping out with junction box: In this system a pair of conductors from the distribution board is brought to the junction box and tapings are taken to switches, two plate ceiling roses as well as other points from the junction box are shown in Fig 8. This method may be economical for lodges where a row of rooms are constructed on either side of a common corridor.

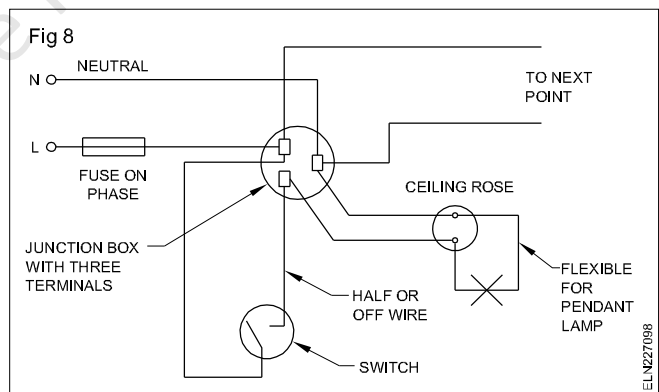

Distribution board system

Advantages:

- 1 All loads are connected across the same voltage
- 2 Fault location is easy.

Disadvantages:

- 1 Requires skilled labour
- 2 Costlier than other systems.

Comparison of different types of wiring at a glance is given in the following table.

Different types of wiring at a glance

Sl. No.	Particulars	Casing & Capping PVC (Poly Vinyl Chloride)	Batten wiring		Conduit wiring	
			TRS (Tough Rubber Sheathed)	LCC (Lead Covered Cable)	Metal	PVC
1	Material	PVC casing and capping PVC wires wooden gutties screws, blocks and boards.	T.W.Batten TRS/CTS wires gutties, screws, nails, clips, board & blocks.	Batten lead covered wire gutties, screw clips, board and blocks.	Metal conduit pipe, saddles hooks, wooden gutties, bend and socket and other accessories screws, block and board.	PVC conduit pipe, saddles, hooks, wooden gutties, bend and socket and other accessories screws block and board.
2	Cost	Fairly cheap	Cheap	Expensive	Expensive	Cheap
3	Life	Fairly long	Long	Long	Very long	Long
4	Mechanical Protection	Fair	Fair	Good	Very good	Good
5	Protection	Bad	Fair	Fair	Very good	Bad
6	Safety	Fair	Good	Good	Very good	Fair
7	Labour	Skilled	Skilled	Skilled	Highly skilled	Skilled
8	Extension and removal	Easy	Easy	Difficult	Not so easy and costly.	Easy
9	Time	Fairly short	Short	Fairly long	Very much longer	Fairly long
10	General reliability	Good	Fairly good	Fairly good	Very good	Good
11	Appearance	Good	Good	Good	Very good	Very good
12	Nature of application	Office only for Computer wiring.	Domestic & Office building	Domestic & Office building	Workshop	Domestic

Types of domestic wiring

Objectives: At the end of this lesson you shall be able to

- explain the layout, installation plan, circuit -diagram, wiring diagram and state their uses
- state the B.I.S. regulation pertaining to wiring installation.

In electrical wiring work, the electrician is supplied with a layout of wiring installation and an installation plan initially.

On the basis of the layout and installation plan, the electrician should draw the circuit and wiring diagrams before the commencement of work for systematic execution of the work.

The terms used in wiring installation drawings are explained here.

Layout diagram: Some customers give their requirements in writing. But a few can give them in the form of a layout diagram to the electrician. In the case of a written requirement, the electrician will prepare a layout diagram and then get the approval of the consumer.

The layout diagram (Fig 1) is a simplified version of the wiring diagram. Its purpose is to inform the reader quickly and exactly, what the circuit is designed for without giving any information on the circuit itself.

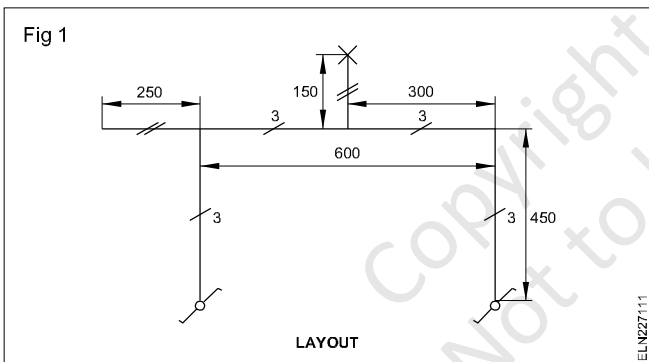

This type of layout diagram is used for preparing architectural diagrams, plans, etc. of a building.

In a layout diagram, it is necessary to indicate with symbols details like whether the wiring is on the surface or concealed, and the run 'up' or 'down', the number of wires in run, dimensions, and accessories with appropriate I.S. symbols.

Normally the layout plan is drawn and then the wiring diagram. After completion of the wiring diagram, the number of cables to be run in each cable run and the size of conduit or batten are estimated. With the help of the distance marking in the layout plan, the estimation of cables, could be made.

Installation plan (Fig 2): This plan shows the physical position of accessories in an installation, and also gives the final appearance of the installation. It may not be possible to draw the installation plan for the entire layout diagram. But it can be restricted to a small part of the installation to highlight the type of conduit, accessories, spacing of gutties, clamps etc.

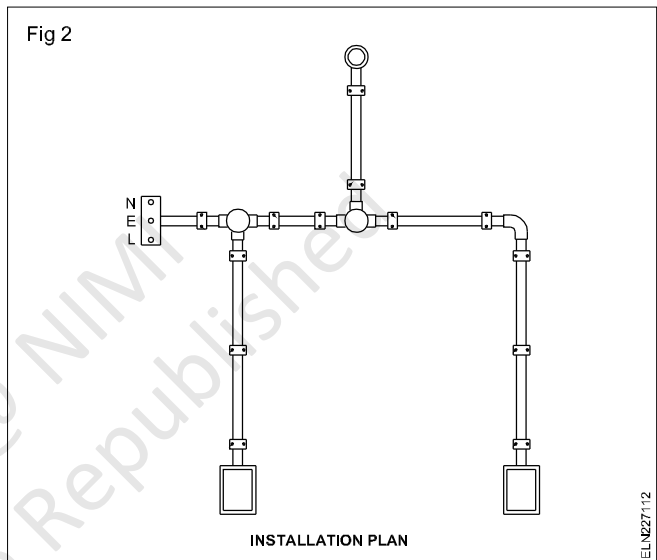

Circuit diagram (Fig 3): This shows the schematic connections of the circuit for a specific task in the simplest form, incorporating the graphical symbols.

The purpose of a circuit diagram is to explain the function of the various accessories in the circuit. Fig 3 is an example of a circuit diagram for controlling a lamp from two different places.

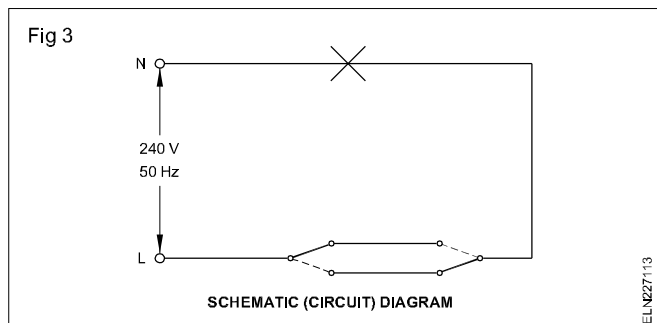

Wiring diagram (Fig 4): This is the diagram in which the position of the components in the diagram bears a resemblance to their actual physical position.

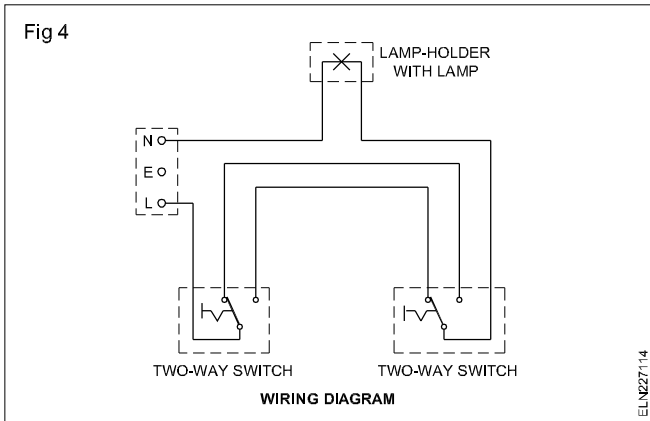

The wiring diagram may not have distance marking. Use of the wiring diagram along with the layout diagram enables the technician in the initial stages of the planning to specify/estimate the required type, size and length of the cables, and also to decide on the vertical, horizontal and ceiling runs of the cable. The wiring diagram is of great use to test and rectify faults in the installation during maintenance work. Fig 4 also shows the wiring plan for controlling a lamp from two different places with their actual locations.

For his own good and to facilitate quick location of faults at a later stage, the customer should insist on the electrician giving him a copy of the wiring diagram soon after the completion of wiring. The electrician should make it a point to do so.

B.I.S. Regulations and the N .E. code pertaining to wiring installations

The wiring installation shall generally be carried out in conformity with the requirements of the Indian Electricity Act 1910, as updated from time to time and the Indian Electricity Rules 1956, framed thereunder, and also the relevant regulations of the electric supply authority of the concerned area (State Government).

To govern the installation of electrical wirings in buildings, with particular reference to safety and good engineering practice, the Indian Standard is published.

The following are some of the extracts of B.I.S. (Bureau of Indian Standards) regulations pertaining to wiring installations. All the B.I.S. regulations are recommended by the National Electrical Code (NEC).

B.I.S. regulations pertaining to wiring installations

Wiring: Any one of the following types of wiring may be used in a residential building.

- Tough rubber-sheathed or PVC-sheathed or batten wiring.
- Metal-sheathed wiring system
- Conduit wiring system:
 - a rigid steel conduit wiring
 - b rigid non-metallic conduit wiring
- Wood casing wiring

Fittings and accessories: All fittings, accessories and appliances used in wiring installations shall conform to Indian Standards. (I.S. mark)

The system should provide easy access to fittings for maintenance and repair, and for any possible modification to the system. Modifications to the system shall be done only by licensed electrical contractors, licensed under the Indian Electricity Rules.

Sub-circuits - different types: The sub-circuits may be divided into the following two groups:

- Light and fan sub-circuit
- Power sub-circuit.

After the main switch, the supply shall be brought to a distribution board. Separate distribution boards shall be used for light and power circuits.

Light and fan sub-circuits: Lights and fans may be wired on a common circuit. Each sub-circuit shall have not more than a total of ten points of lights, fans and 6A socket-outlets. The load on each sub-circuit shall be restricted to 800 watts. If a separate circuit is installed for fans, the number of fans in that circuit shall not exceed ten.

Power sub-circuits: The load on each power sub-circuit should normally be restricted to 3000 watts. In no case shall there be more than two outlets on each sub-circuit.

If the load on any power sub-circuit exceeds 3000 watts, the wiring for that sub-circuit shall be done in consultation with the supply authority.

A switch shall be provided adjacent to the normal entrance to any area for controlling the general lighting in that area. The switches should be fixed on a usable wall space and should not be obstructed by a door or window in its fully open position. They may be installed at any height up to 1.3m above the floor level.

Two-way switching is recommended for halls and staircases.

Switches and bell pushes should preferably be self-illuminating where they are often operated in dark.

Deep, dark cupboards and larders may be fitted with a lighting outlet, preferably with a door switch.

The light fittings in kitchens should be so placed that all working surfaces are well illuminated and no shadow falls on them when in normal use.

In living and dining rooms, if a cover or valance is provided, a lighting outlet should be provided, and it should have a separate switch.

In bedrooms it is recommended that some lighting be controlled from the bed location.

For bathrooms, it is recommended to use ceiling lighting with the switch located outside the bathroom. Alternatively an insulated cord-operated switch may be used. However, if the light switch is installed inside the bathroom, it should be out of reach of a person in a bath-tub or under the shower. Touching a switch with wet hand is highly dangerous.

It is recommended that lighting facilities be provided for lighting of all steps, walkways, driveways, porch, carport, terrace, etc, with switches for each provided inside the house at a convenient place. If the switches are installed outdoors, they should be weatherproof.

Waterproof lighting fittings should be used for outdoor lighting.

Socket-outlets: All plugs and socket-outlets shall be of 3-pin type, the appropriate pin of the socket being connected permanently to the earthing system.

An adequate number of socket-outlets shall be placed suitably in all rooms so as to avoid the use of long lengths of flexible cords.

Only 3-pin, 6A socket-outlets shall be used in all light and fan sub-circuits. 3 pin, 16A socket-outlets shall be controlled by individual switches which shall be located immediately adjacent to it. For 6A socket-outlets, if installed at a height of 130 cm above the floor level, in situations where a socket-outlet is accessible to children, it is recommended to use shuttered or interlocked socket-outlets.

In case an appliance requiring the use of a socket-outlet of a rating higher than 16A is to be used, it should be connected through a double-pole switch of appropriate rating.

Socket outlets shall not be located centrally behind the appliances with which they are used. Socket-outlets shall be installed either 25 or 130 cm above the floor as desired.

It is recommended that 3-pin, 6A socket-outlets may be provided near the shelves, bookcases, clock positions, probable bed positions etc.

Depending on the size of the kitchen, one or two 3-pin, 16A socket-outlets shall be provided to plug in hot plates and other appliances. Dining rooms, bedrooms, living rooms, and study rooms, if required, shall each be provided with atleast one 3-pin, 16A socket outlet.

No socket-outlet shall be provided in the bathroom at a height less than 130 cm.

A recommended schedule of socket-outlets is given below.

Location	6A Outlets	16A Outlets
Bedroom	2 to 3 Nos.	1 No.
Living room	2 to 3 Nos.	2 Nos.
Kitchen	1 No	2 Nos.
Dining room	2 Nos	1 No.
Garage	1 No	1 No.
Refrigerator	-	1 No.
Air-conditioners	-	1 No.
Verandah	1 No.	1 No.
Bathroom	1 No.	1 No.

Multi-plug adaptors for connecting more than one appliance to one socket outlet should not be used.

Fans: Ceiling fans shall be wired to ceiling roses or to special connector boxes. All ceiling fans shall be provided with a switch besides its regulator.

Fans shall be suspended from hooks or shackles with insulators between the hooks or shackles and also with insulators between the hooks and suspension rods.

Unless otherwise specified, all ceiling fans shall be hung not less than 2.75 m above the floor.

Flexible cords: Flexible cords shall be used only for the following purposes.

- For pendants
- For wiring of fixtures
- For connection of transportable and hand-held appliances

Flexible cords shall not be used in the following cases.

- As a substitute for the fixed wiring.
- Where cables may have to run into holes through the ceiling, walls, floors, windows, etc.
- For concealed wiring.
- If attached permanently to the walls, ceilings, etc.

Mounting levels of the accessories and cables as recommended in B.I.S. and N.E.C.

Height of main and branch distribution boards should be not more than 2m from the floor level. A front clearance of 1 m should also be provided.

All the lighting fittings shall be at a height of not less than 2.25 m from the floor.

A switch shall be installed at any height 1.3 m above the floor level.

Socket-outlets shall be installed either 0.25 or 1.3 m above the floor as desired.

The clearance between the bottom point of the ceiling fan and the floor shall be not less than 2.4 m. The minimum clearance between the ceiling and the plane of the blades of the fan shall not be less than 300 mm.

The cables shall be run at any desired height from the ground level, and while passing through the floors in the case of wood casing and capping and T.R.S. wiring, it shall be carried in heavy gauge conduit 1.5 m above floor level.

References

- I.S. 732-1963
- I.S. 4648-1968
- N.E. Code

Method of marking the layout for wiring

Objective: At the end of this lesson you shall be able to

- list the tools required for layout marking and state the method of marking the layout for wiring.

When installing electrical wiring in a building, it is necessary to mark the layout on the ceiling and walls to indicate the position of the various fittings and appliances to be installed and the routing of the cable runs.

To assist in the marking of the layout on the walls and ceilings, the following tools are used.

- Plumb bob or plummet
- Spirit-level
- Water-level

Plumb bob: A plumb bob consists of a block and a weight attached to each other by a string through their centres. When the plumb bob is placed on the wall, the weight is made to hang vertically through the string and the plumb line (string) indicates the true vertical (Fig 1).

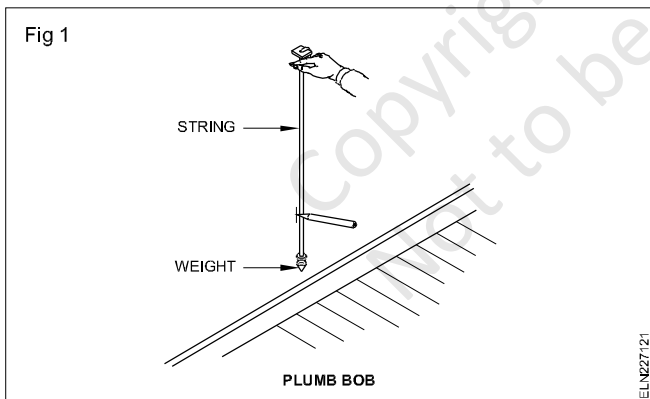

Spirit-level: This consists of a level tube set in a straight edge. When the air bubble in the level tube locates centrally between the markings on the tube, the surface on which the straight edge is kept, it is deemed to be in a horizontal position. Spirit-levels are usually available in sizes from 150 mm to 1 m long (Fig 2).

Water-level: A water-level consists of two calibrated glass tubes which are connected together by a flexible rubber tube. The tube is filled with water until the level is halfway up in both the glass tubes. The glass tubes shall be sealed when not in use. Instead of glass tubes on either side of a non-transparent tube, we can use an ordinary transparent PVC tube as water level (Fig 3).

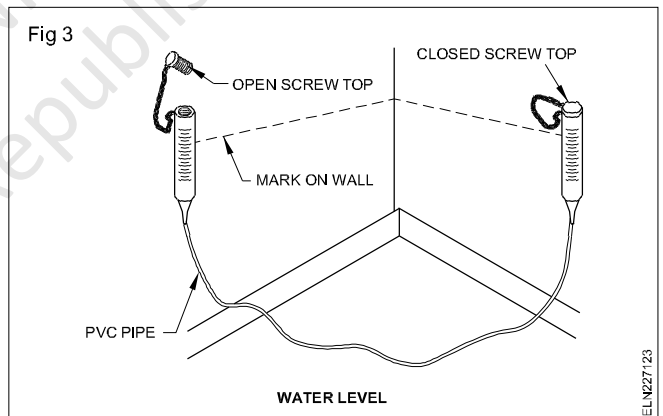
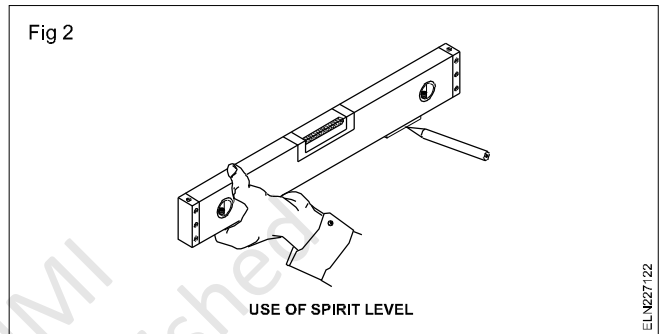

Marking of layout: For marking of layout on walls and ceilings of an installation, chalking lines are used. Fine chalk powder is dusted on to a twine thread. When the twine thread dusted with chalk powder is held taut against a wall and 'plucked', it marks the wall with a fine line of chalk dust.

Marking of true vertical runs: For marking the vertical lines, a 'plumb bob' also known as plumb line, is generally used. A 'plumb line' is used in the following manner.

Determine the position of the vertical line to be marked.

Hold the string(line) between the finger and the thumb at an appropriate distance from the weight to correspond with the height of the vertical line position marked.

Suspend the weight just clear of the floor or other obstructions, such as skirting boards, and rest the thumb against the wall and hold it steady until the string and the plumb bob are at rest, just clear of the wall's surface, at the location required as in Fig 1.

Make two pencil or chalk marks on the wall at least 1 metre apart to correspond with the line of the string.

Draw a line joining the two marks using a straight edge and extend the lines as necessary.

For marking chalking twine (string) lines, stretch out the chalking twine, pull out a sufficient length for the height of the line required.

Hold the lower end with one foot and pull the string taut, adjusting the foot and hand as necessary until the line is directly over the two pencil marks on the wall. (Instead of holding the string with your foot, another person may be asked to assist.)

Use the free hand to lift the tautly held string about 20-30 mm away from the wall and release it. The string springs back to deposit a line of chalk dust on the surface of the wall (Fig 4).

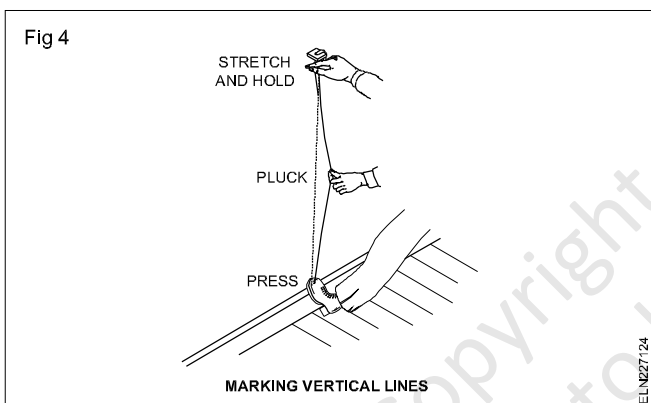

A chalking line is usually used to mark long lines.

Marking 'true' horizontal runs: The horizontal run is marked either by using a spirit-level or a water-level. Generally for electrical works, a spirit-level is used.

Mark the horizontal lines as outlined below.

Determine where you want the horizontal line to be drawn, using dimensions from the drawings and measuring off the fixed features such as the floor or ceiling. Make a single mark on the wall at the required height.

Hold the spirit-level with both hands and line it up with the mark on the wall.

Check the position of the air bubble in relation to the markings on the tube. Adjust the spirit-level until the bubble comes to rest exactly in the centre of the two markings.

Finally hold the level in position with one hand, and with the free hand draw a pencil line along the straight end of the level (Fig 2).

Use the straight edge of the level and line it up with the line already made and extend the pencil mark to the left and right of the original line.

Where long lines are required, repeat the above steps in the desired direction of the wall.

Measuring of horizontal and vertical runs: Horizontal lines can also be drawn by measuring off from a common base. For drawing horizontal lines on the walls, the common base could either be the floor, top of the skirting board or ceiling surface, provided the floor or the ceiling is reasonably level and even.

This method of measuring is used in many situations where installations are made parallel to existing features such as door frames, and skirting boards.

Marking cable runs on the ceiling: For marking on the ceiling, choose two adjoining walls which are at right angles to each other. Taking these walls as the base, take the measurement of the cable run route centres.

Keep the chalk-powdered string on the marking jointly by holding the edges of the string with the help of assistants and pull the strings hard to make the chalk marking on the ceiling.

Methods of connections in domestic wiring installations

Objectives: At the end of this lesson you shall be able to

- explain the looping-back (loop-in) method
- explain the joint-box method.

Introduction

The circuit diagram of a sub-circuit of six lamps, three controlled separately by one-way switches, and three controlled as a group by a one-way switch (Fig 1). If the circuit were wired exactly as in the circuit diagram, a large number of joints would be necessary which are to be done in joint boxes only resulting in an increase in cost and labour. Two methods are adopted to execute the wiring economically. They are 1) the looping-back method and 2) the joint-box method.

Looping-back (loop-in) method

In this method, no separate joints are used. Instead twisted joints are used at the terminals of the accessories themselves. (In switches and ceiling roses)

Where the looping-back system of wiring is specified, the wiring shall be done without any junction or connector boxes on their line.

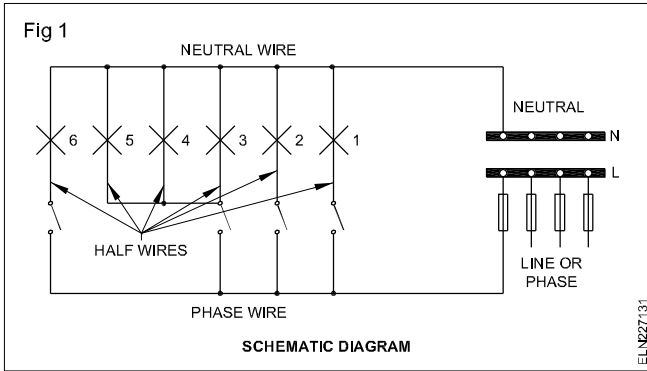

In domestic wiring installation, the looping-back system should be preferred.

The loop-back system can be adopted with two variations.

Loop-in method using 2-plate ceiling roses and switches: Fig 2 shows the schematic diagram of the circuit (Fig 1) as wired by the looping-in system. No separate joints are required in joint boxes. Twisted joints in the terminals of the two-plate ceiling roses and of the switches are, however, required. The schematic diagram (Fig 2) is not practicable and cannot be acceptable in any of the wiring systems like conduit, wooden batten or casing and capping system as it is generally necessary to run the cables close together in the same conduit, batten or casing.

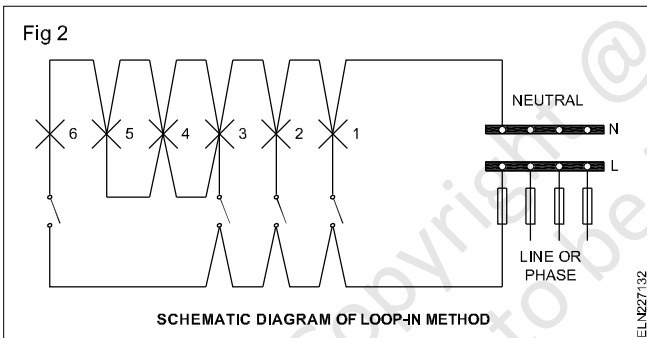
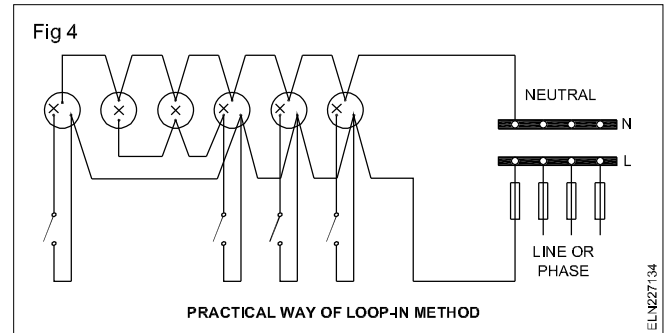
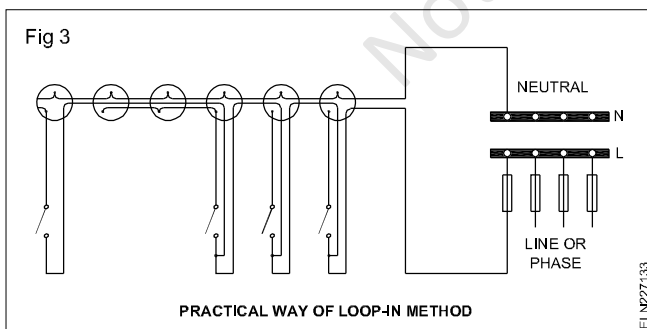

Fig 3 shows the same circuit suitable for practical work.



Loop-in method by 3-plate ceiling rose: We can also use 3-plate ceiling roses (Fig 4). Considerable cable length could be saved by using the third terminal of the ceiling rose as a looping-in terminal for the switch drop, so that two cables only are required from the ceiling rose to the switch.

Joint-box method

In the joint-box method, wherever tapping has to be taken from the cable, joints are made. All joints in cable conductors shall be made by means of porcelain connectors or connector-boxes, and housed in suitable joint-boxes.

In any wiring system no bare or twist joints shall be made at intermittent points in the cable run of the main circuit or sub-circuit. If joining is unavoidable, such joints shall be made through proper cut outs or drawn through proper junction-boxes open for easy inspection.

The joint-box method of wiring system a pair of cables from the switches and ceiling roses will terminate in the junction box. The junction-box is kept in between the light points and switches for economy in the cable length (Fig 5).

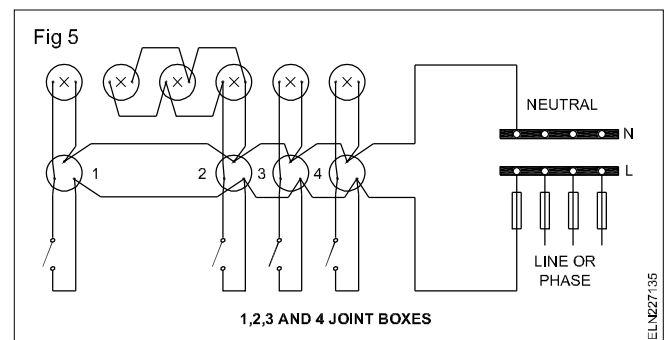

Selection of the type and size of cable for a given wiring installation

Objectives: At the end of this lesson you will be able to

- state the factors to be considered for selecting the cable for a circuit
- apply the factors and select the cable.

In order to determine the type and size of the cable for a given circuit, the following points should be taken into account.

- Suitability of the type of cable for the location of the circuit and the type of wiring.

- Size of the cable depending upon the current carrying capacity of the cable.
- Size of the cable depending upon the length of the wiring and permissible voltage drop in the cable.
- Minimum size of the cable based on the economy.

Location of the circuit and the type of wiring decide the type of cable.

It is necessary to consider whether the installation is for industry or domestic use and whether the atmosphere is damp or corrosive. Accordingly the type of cable has to be chosen.

Further the type of wiring determines the type of cable suitable for the installations.

The current carrying capacity of the cable decides the size of the cable.

In this, the first step is to find out the current expected to flow in the circuit when the total connected load is fully switched on. This current is the maximum current that would flow through the circuit in case all the loads are working at the same time. But this is not the case in actual situations.

Diversity factor

In the case of lighting installation all the lamps in a domestic installation may not be switched 'on' at the same time. Hence, it is assumed only two thirds of the lights (say 66%) only will be 'on' at a given time. This introduces a factor called 'diversity factor'.

When the connected load is multiplied by the diversity factor you get a load value which can be said as normal working load. Use of this diversity factor enables the technician to use a lesser size cable than the one calculated, based on the connected load. The suggested diversity factor according to IEE rules is given in Table 2.

Based on the working load the current in each circuit is to be calculated and the size of the cable suitable to carry the current has to be chosen from Tables 3, 4 and 5.

Voltage drop in the cable

In any current carrying conductor, voltage drop takes place due to its internal resistance. This voltage drop in a premises as per BIS 732 should not be more than 3 percent of the standard supply voltage when measured between the consumer supply point and any point of the installation when the conductors are carrying the maximum current under the normal conditions of service.

Tables 3 and 4 for aluminium cable and 5 for copper cable give the relation between voltage drop and length of the cable run for various cables. In case the voltage drop found in the cable exceeds the stipulated limit of 3% voltage drop, the technician has to choose the next bigger sized

cable to maintain the voltage drop within limits.

If the cable size is increased to avoid voltage drop in the circuit, the rating of the cable shall be the current which the circuit is designed to carry. In each circuit or sub-circuit the fuse shall be selected to match the load or the cable rating whichever is minimum, to ensure the desired protection (BIS 732).

Declared voltage of supply to consumer

On the other hand according to IE Rule No.54, the voltage at the point of commencement of supply at the consumer should not vary from the declared voltage by more than 5 percent in the case of low or medium voltage or by more than 12 percent in the case of high or extra high voltage (Fig 1).

At this stage it is better to remember that when current

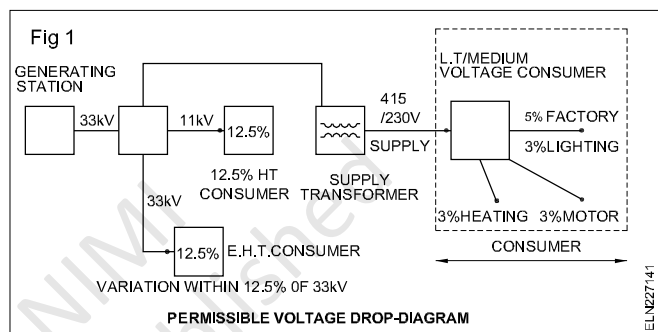

flows through a conductor, the resistance offered by the conductor produces heat. The increase in heat is proportional to the cable resistance which in turn depends upon the cross-sectional area of the cable. Since overheating damages the insulation, the conductor size must be adequate to prevent this from occurring.

While choosing the cable size, voltage drop is a more severe limitation than any other criterion. Hence, it is advisable to select the cable size only after ascertaining the permissible voltage drop. Excessive voltage drop impairs the performance of heating appliances, lights and the electric motors.

Calculation of voltage drop

In DC and single phase AC two-wire circuits

$$\begin{aligned} \text{Voltage drop} &= \text{Current} \times \text{Total resistance of cables} \\ &= 2 IR \end{aligned}$$

where I is the current and

R is the resistance of one conductor only

Wherever voltage drop is given as 1 volt drop per metre run of cable, we have to assume that both (lead and return) cables are taken into account and the cable carries its rated current. In such cases the voltage drop for X metre length of cable for a current of Y amps is calculated as given.

$$\left\{ \begin{array}{l} \text{Voltage} \\ \text{drop} \end{array} \right\} = \frac{\left\{ \begin{array}{l} \text{Length of} \\ \text{the cable} \end{array} \right\} \times \left\{ \begin{array}{l} \text{Actual current} \\ \text{of the load} \end{array} \right\}}{\left\{ \begin{array}{l} \text{Metre length of} \\ \text{the cable per one} \\ \text{volt drop} \end{array} \right\} \times \left\{ \begin{array}{l} \text{Rated current} \\ \text{of the cable} \end{array} \right\}}$$

$$= \frac{XY}{\left\{ \begin{array}{l} \text{Metre length of} \\ \text{the cable per one} \\ \text{volt drop} \end{array} \right\} \times \left\{ \begin{array}{l} \text{Rated current} \\ \text{of the cable} \end{array} \right\}}$$

3-phase circuits

$$\text{Voltage drop} = 1.73 \times I R = \sqrt{3} IR$$

where I is the line current
R is the resistance of one core only.

The above points could be explained through the following set of examples.

Example 1

A guest house installation has the following loads connected to the three phase 415 V supply with neutral. Select a proper size of cable for this installation.

- Lighting - 3 circuits of tungsten lighting total 2860 watts
- Power from 3 x 30A ring circuits to 16A socket outlets for
 - 1 x 7 KW Water heater (Instant)
 - 2 x 3 KW Immersion heater (Thermostatically controlled)
- Cooking appliances:
 - 1 x 3 KW cooker
 - 1 x 10.7 KW cooker

Current demand in amperes in each of the circuit is calculated by referring the Table 1. Calculation of current taking account into the diversity factor from Table 2.

Assuming the declared voltage as 240 volts and the length of the longest run in a circuit as 50 metres

Permissible voltage drop at the rate of 3%

$$= \frac{3 \times 240}{100} = 7.2 \text{ Volts}$$

Referring to Table 3, if the size of the conductor selected is 35.0 sq.mm which can carry 69 amps, the voltage drop at 69 amperes rating will be 1 volt for every 7.2 metres cable run.

For 50 metres cable run the voltage drop at 69 amps current rating = 50 / 7.2 volts.

Voltage drop for 65 amps

$$= \frac{50 \times 65}{7.2 \times 69} = 6.54 \text{ Volts}$$

As the actual voltage drop in the circuit, that is 6.54 volts, is well within the permissible value, of 7.2 volts, the cable selected is suitable for the installation.

Table 1

Sl. No	Demand description	Current Demand (Ampere)	Diversity Factor (Table 2)	Current allowing for Diversity (Ampere)
1	Lighting	11.9	75%	9.00
2	Power i	30	100%	72.00
	ii	30	80%	
	iii	30	60%	
3	Water heaters (inst)	29.2	100%	29.2
4	Water heaters (thermo)	25.00	100%	25.00
5	Cooker i	12.5	80%	10.00
	ii	44.5	100%	44.5
Total current = 213.1				189.7
Total current demand (allowing diversity) = 189.7 amps Load spread over 3 phases = 189.7/3 = 63.23 amps, say 65 amps per phase.				

Example 2

A three-phase 3-wire connection is to be given to a premises in which an electric motor of 50 H.P. is to be installed. 40 metres of cable run from the main switch is required for this purpose. Determine the size of the 3-core cable to be used, if the available voltage is 400 V 50 Hz (Assuming PF is 0.8).

$$\left\{ \begin{array}{l} \text{Current drawn by the motor} \end{array} \right\} = \frac{50 \times 746}{\sqrt{3} \times 400 \times 0.8} = 67.3$$

As a 3-core cable is used, referring to Table 4 it will be seen that 35 sq.mm. (7/2.5) PVC cable will be in a position to carry the motor current safely.

$$\left\{ \begin{array}{l} \text{The Permissible} \\ \text{Voltage drop} \end{array} \right\} = \frac{400 \times 3}{100} = 12 \text{ Volts}$$

But as per Table 4, the selected cable will have 1 volt drop for every 7.1 m cable run.

Hence, for 40 metres the voltage drop is = 40 / 7.1 volts = 5.63 volts.

Referring to Table 4 we have voltage drop at 69 amps = 5.63 volts.

Hence the voltage drop at 67.3 amp is

$$= \frac{40 \times 67.3}{7.1 \times 69} = 5.49 \text{ Volts}$$

As the drop is within permissible limits, of 12V, the 3-core PVC cable size 35 sq.mm (7/2.5) is suitable.

TABLE 2
Allowances for diversity

Purpose of final circuit fed from conductors or switchgear to which diversity applies	Individual household installations, including individual dwellings of a block	Small shops, stores, offices and business premises.	Small hotels, boarding houses
1 Lighting	66% of total current demand	90% of total current demand	75% of total current demand
2 Heating and power (but see 3 to 8 below)	100% of total current demand up to 10 amperes + 50% of any current demand in excess of 10 amperes.	100% FLC of largest appliance + 75% FLC of remaining appliances.	100% of FLC of largest appliance + 80% FLC of 2nd largest appliance + 60% FLC of remaining appliances
3 Cooking appliances	10 amperes = 30% FLC of connected cooking appliances in excess of 10 amperes + 5 amperes if socket outlet incorporated in unit.	100% FLC of largest appliance + 80% FLC of 2nd largest appliance + 60% FLC of remaining appliances	100% FLC of largest appliance + 80% FLC of 2nd largest appliance + 60% FLC of remaining appliances
4 Motors (other than lift motors which are subject to special consideration)	100% FLC of largest motor + 80% FLC of 2nd largest motor + 60% FLC of remaining motors.		100% FLC of largest motor + 50% FLC of remaining motors.
5 Water heaters (instantaneous type)*	100% FLC of largest appliance + 100% FLC of 2nd largest appliance + 25% FLC of remaining appliances.	100% FLC of largest appliance + 100% FLC of 2nd largest appliance + 25% FLC of remaining appliances	100% FLC of largest appliance + 100% FLC of 2nd largest + 25% FLC of remaining appliances.
6 Water heaters (thermostatically controlled)		No diversity allowable.	
7 Floor warming installations		No diversity allowable.	
8 Thermal storage space heating installations		No diversity allowable.	
9 Standard arrangements of final circuits in accordance with Appendix 5	100% of current demand of largest circuit + 40% of current demand of every other circuit.	100% of current demand of largest circuit + 50% of current demand of every other circuit.	
10 Socket outlets other than those included in 9 above	100% of current demand of largest point of utilisation + 40% of current demand of every other point of utilisation.	100% of current demand of largest point of utilisation + 75% of current demand of every other point of utilisation.	100% of current demand of largest point of utilisation + 75% of current demand of every point in main rooms (dining rooms etc.) + 40% of current demand of every other point of utilisation.

* For the purpose of this table an instantaneous water heater is deemed to be a water heater of any loading which heats water only while the tap is turned on and, therefore, uses electricity intermittently. It is important to ensure that the distribution boards are of sufficient rating to take the total load connected to them without the application of any diversity.

Table 3

Current ratings and voltage drop for vulcanised rubber PVC or polythene insulated or tough rubber PVC lead sheathed, single core, aluminium wires or cables

Size of conductor		2 cable DC or single phase AC		3 or 4 cables balance 3 phase		4 cables DC	
Nominal area sq.mm	No. and diameter of wire in metres	Current rating in amperes	Approx. length of run for 1 volt drop in metres	Current rating in amperes	Approx. length of run for 1 volt drop/ metre	Current rating in amperes	Approx. length of run for 1 volt drop in metres
1.5	1/1.40	10	2.3	9	2.9	9	2.5
2.5	1/1.80	15	2.5	12	3.6	11	3.4
4.0	1/2.24	20	2.9	17	3.9	15	4.1
6.0	1/2.80	27	3.4	24	4.3	21	4.3
10.0	1/3.55	34	4.3	31	5.4	27	5.4
16.0	7/1.70	43	5.4	38	7.0	35	6.8
25.0	7/2.24	59	6.8	54	8.5	48	8.5
35.0	7/2.50	69	7.2	62	9.3	55	9.0
50.0	7/3.0 19/1.80	91	7.9	82	10.1	69	10.0

TABLE 4

Current ratings and voltage drop for vulcanised rubber, PVC or polythene insulated or tough rubber, PVC lead sheathed, twin, three or four cores aluminium wires or cables

Nominal area sq. mm.	No. and diameter of wire in metres	Current rating in amperes	Approx. length of run for 1 voltage drop/ metre	Current rating in amperes	Approx. length of run for 1 volt drop in metres
1.5	1/1.40	10	2.3	7	3.7
2.5	1/1.80	15	2.5	11	1.9
4.0	1/2.24	20	2.9	14	4.8
6.0	1/2.80	27	3.4	19	5.5
10.0	1/3.55	34	4.2	24	6.8
16.0	7/1.70	43	5.3	30	8.7
25.0	7/2.24	59	6.6	42	10.8
35.0	7/2.50	69	7.1	48	11.7
50.0	7/3.00 19/1.80	91	7.7	62	13.1
70.0	19/2.24	118	8.8	82	14.7
95.0	19/2.50	135	9.5	94	15.7
120.0	37/2.06	162	10.3	114	16.8

TABLE 5

Wattage loading of small VR Insulated copper conductor cables

Maximum permissible loading in watts at unity power factor for two single core cables in one conduit based on IEE current ratings subject to voltage drop

Cable Size			Current rating amp	Circuit Voltage		Approximate voltage drop per 10 metres run with current in Col 4. volts
mm	inch	approx. area in mm		230V watts	250 V watts	
1	2	3	4	5	6	7
1/1.11	1/0.44	1	5	1150	1250	1.97
3/0.74	3/0.29	1.2	10	2300	2500	3.09
3/0.91	3/0.36	2	15	3450	3750	2.98
7/0.74	7/0.29	3	20	4600	5000	2.64
7/0.91	7/0.36	4.5	28	6440	7000	2.37
7/1.11	7/0.44	6.75	36	8280	9000	2.04
7/1.32	7/0.52	9.5	43	9890	10750	1.75
7/1.62	7/0.64	15	53	12190	13250	1.42
19/1.11	19/0.44	18	62	14260	15500	1.30
19/1.32	19/0.52	25	74	17020	18500	1.11
19/1.62	19/0.64	38.75	97	22310	24250	0.96

Metal conduit pipe - methods of cutting, threading and bending

Objectives: At the end of this lesson you shall be able to

- state the methods of cutting a metal conduit pipe
- state the purpose and process of threading and list out the precautions of conduit pipes
- list the different accessories used in conduit installation
- state the purpose and methods of bending the conduit pipes and list out the precautions.

Cutting: Rigid and intermediate conduits may be cut with a hacksaw (Fig 1) or a pipe cutter (Fig 2). With either method, the conduit must be locked in a pipe vice before making the cut. Fix the conduit in the vice so that the vice grips the conduit 50 or 75 mm from the point where the cut has to be made. This prevents the grip of the pipe vice from damaging the surface of the conduit that must be threaded.

If a hacksaw is used, use 24 teeth per 25 mm blade. Be sure to install the blade so that the cut is made on the forward stroke.

After cutting (Figs 1 and 2) the inside edge of the conduit must be smoothed with a half round file (Fig 3) or a pipe reamer mounted in a brace.

Be particularly careful while cutting the conduit with a pipe cutting tool. This tool tends to leave a sharp ridge on the

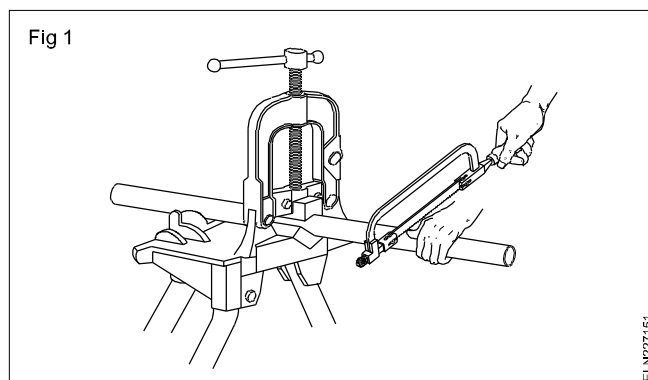

inner edge of the cut. Be sure this ridge is removed and the conduit is smooth before installing a coupling or any fitting, to avoid damage to the insulation of conductors.

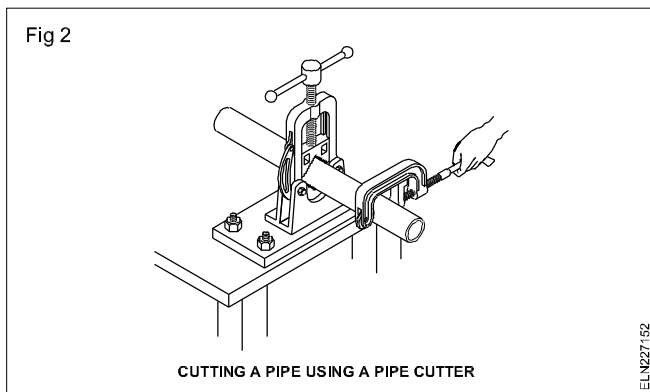

Purpose of threading: When short lengths of conduits are to be used for switch or lamp drops, the cut end of the pipe needs to be threaded to enable fixing of the conduit to accessories. Threads on conduit pipes in all cases shall be between 11 mm to 27 mm long, sufficient to accommodate pipes to the full-threaded portion of couplers or accessories.

Threading: Conduit is threaded by using dies and a die stock. Apply cutting oil to the end of the conduit before starting to cut threads. Cutting the threads longer than necessary will leave the exposed threads subject to corrosion.

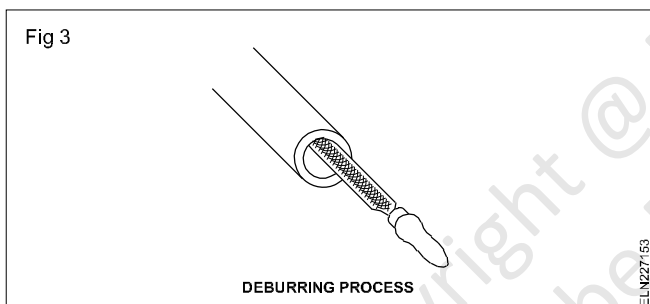

Do not use any lubricant which is an electrical insulator, as this may increase the resistance of the conduit assembly and affect its use as the circuit protective earthing conductor.

Precautions to be observed while threading conduit pipes

- 1 Chamfer the end of the conduit to be threaded. Make the depth of the chamfer equal to the pitch of the thread (1.5 mm for conduit).
- 2 Apply a lubricant frequently while threading the conduit pipe. It helps the die to cut more easily and the die to stay sharp.
- 3 Check whether stock is at right angles to the pipe axis.
- 4 Reverse turnings of the die stock are necessary to break off cut chips and to clear the cutting edges of the die.
- 5 Use only a brush to remove the metal burrs from the die. Do not use your hand.

Conduit accessories

Conduit coupling: As conduits are commercially available in specific lengths only, it has become necessary to join two or more lengths to obtain the required runs. Joining of conduits is done by means of couplers.

There are two types of couplers used for rigid metal conduits as explained below.

Screwed couplers: They are also called running couplers and are made of cast iron, having female threads inside (Fig 4). The conduits to be joined should be threaded to a length sufficiently long to fit half way into the coupling such that no threaded portion is visible outside (Fig 5) to avoid corrosion.

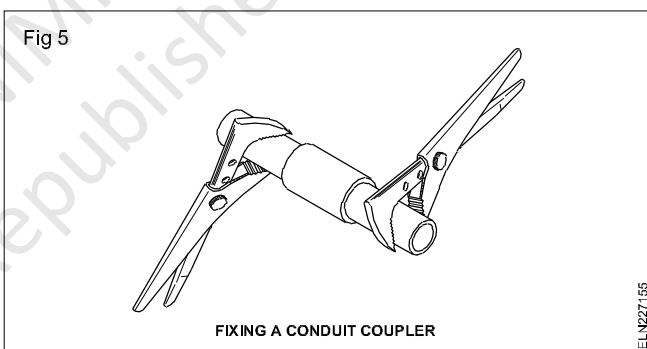
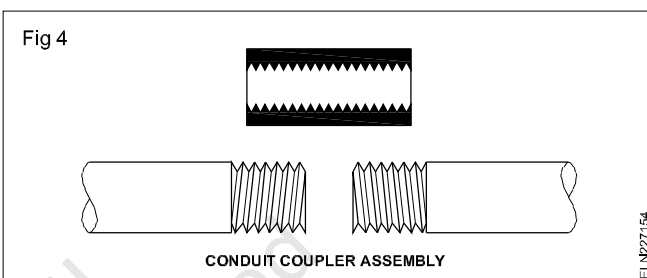

This type of running couplers makes the joint mechanically weaker and electrically non-continuous. Hence the second type of coupler uses a check (jam) nut along with the running coupler which is a much better choice than the running coupler.

Check-nut and running coupler: For using this coupler, one of the conduits should have longer threads to accommodate fully the coupler, and the other conduit should have threads to a length equal to half the length of the coupler (Fig 6).

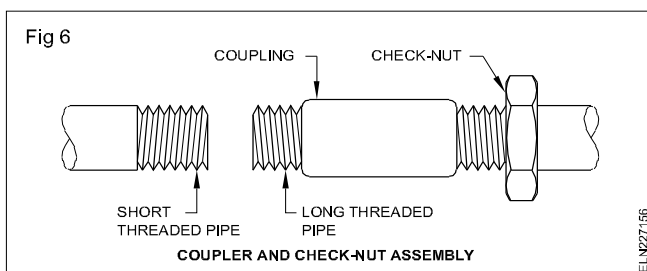

First the check-nut and then the coupler should be screwed inside the long threaded conduit. Then the short threaded conduit is butted with the long threaded conduit and the coupler is screwed on the short threaded conduit tightly.

Then the check-nut is screwed and tightened along the coupler (Fig 7).

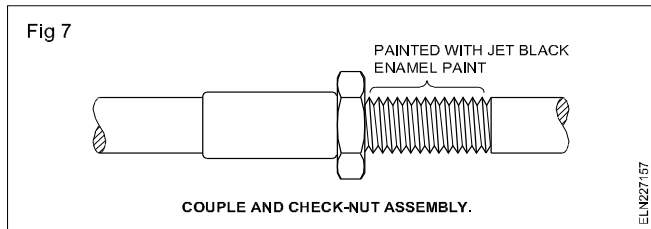

The exposed threaded portion of the long threaded conduit is painted with jet black enamel paint to prevent rust.

Coupling for flexible conduits: For flexible conduits, split couplings are used (Fig 8).

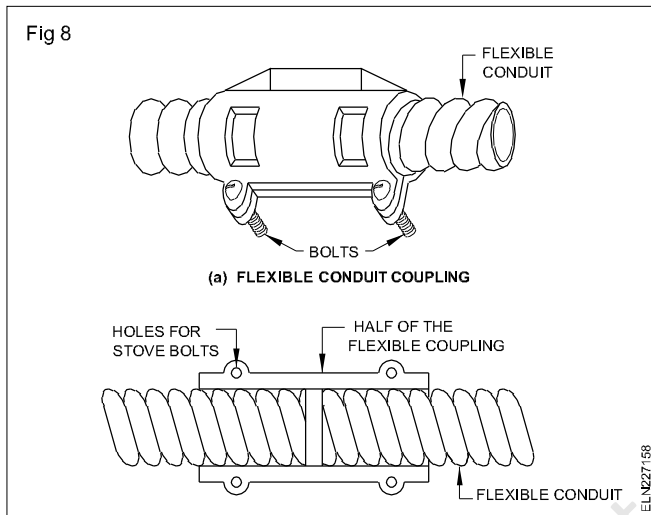

Special type of split couplings (Fig 9) is to be used when the flexible conduit is to be connected to a rigid conduit at places where high flexibility is required. This coupling has threading on one side with the other side made suitable to grip the flexible conduit.

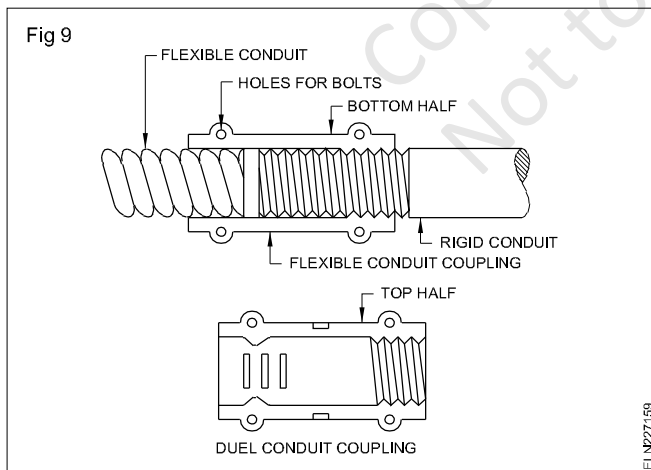

Metal conduit boxes: Termination of rigid conduits is done at metal conduit boxes of either cast iron or sheet metal. Various shapes and sizes of boxes are commercially available in the market. Junction boxes of round, square, rectangular and hexagonal shapes are manufactured for one-way, 2-way, 3-way and 4-way outlets.

These outlets may be straight, angular or tangential as required for the situation. When ordering, the specification should contain the material with which the box is to be made, the size of the conduit to be fitted, the number of ways, shape and the position of outlets.

Example: Cast iron 20 mm, 3-way, round tee.

Fig 10 shows some of the popular types of outlet boxes. Cast iron 20 mm, 3-way, round tee.

Fig 11 shows various types of circular (round) boxes in a single line diagram.

Fig 12 shows typical ceiling boxes, and Fig 13 shows wall boxes whereas Fig 14 shows switch boxes.

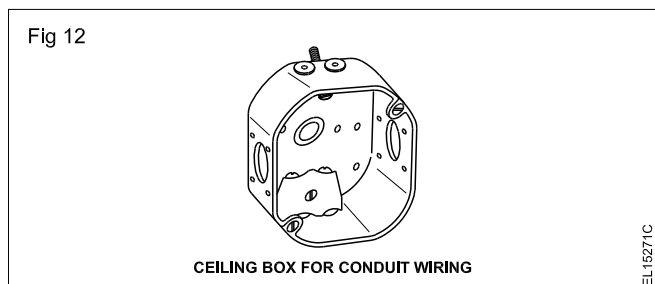
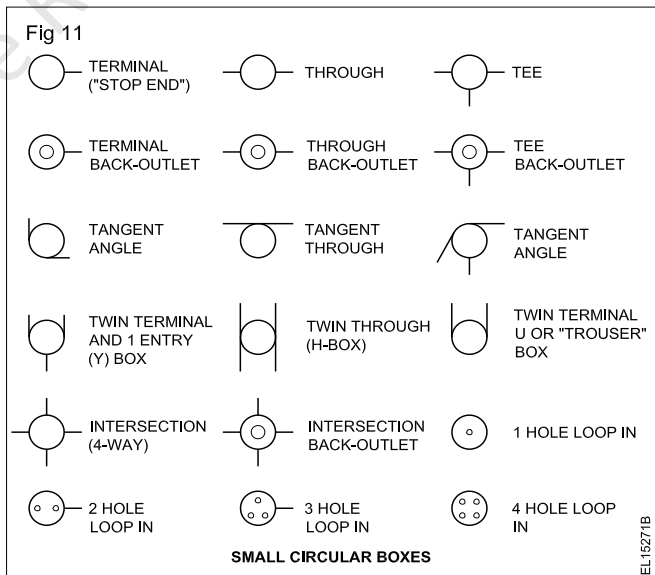
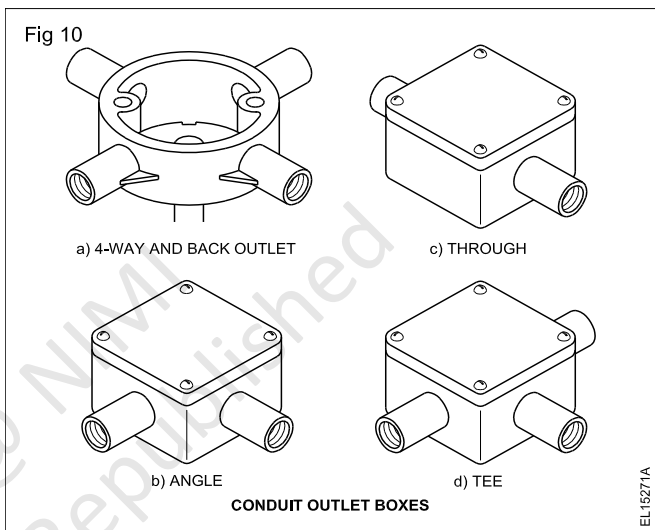

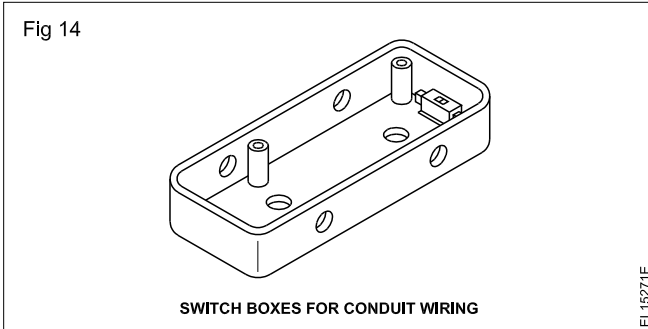
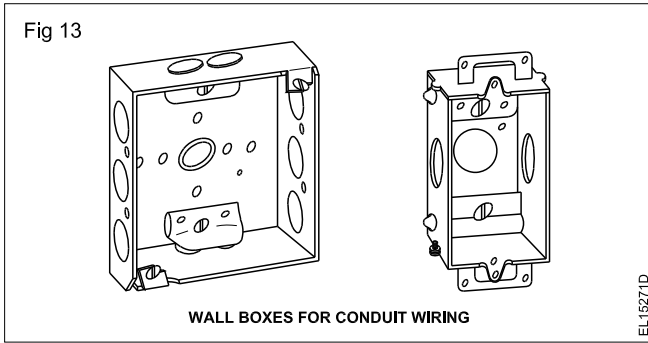

The ceiling, wall and switch boxes are normally provided with knock-out openings which can be removed when required by using punches or chisels with a stroke from a hammer. In some cases the knock-out openings could be made by the pry out-method with a screwdriver (Fig 15).

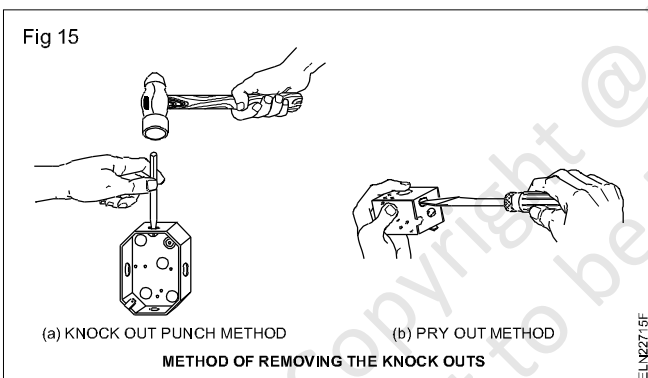

After removing the knock-outs, the conduit is to be fitted in the opening by any one of the methods shown in Fig 16.

However, when brass bushes are not used in the terminating end of the conduits, it is necessary to use PVC bushes at the conduit ends to facilitate easy drawing of the cables and to avoid damage to the cable insulation.

Lock nuts: Hexagonal lock nuts are used at the conduit terminations (Fig 17) to make the terminations mechanically strong and electrically continuous. Remember that the paint at the box entries should be scraped out, before fitting the lock nut in position to facilitate electrical continuity.

Conduit bushings: These are made from brass or malleable iron or PVC and have a smooth large radius edge (Fig 18). This should be used at conduit terminations for dual purposes.

The first purpose is to protect the cable insulation from getting damaged during drawing of the cables, and the

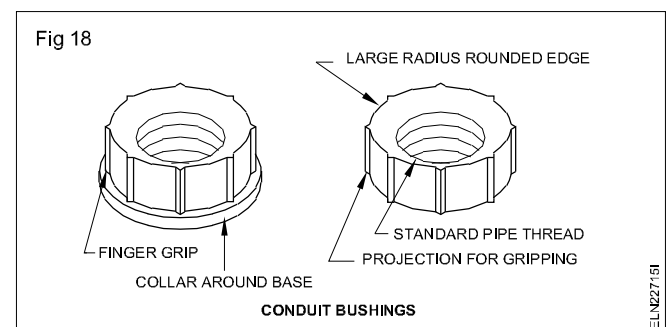
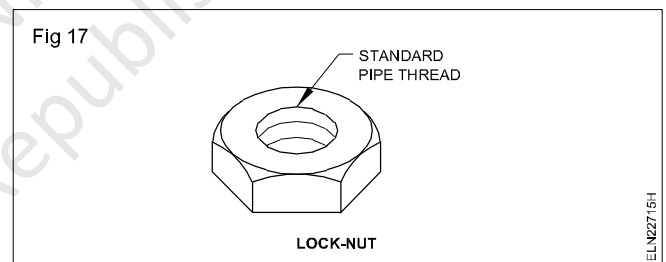
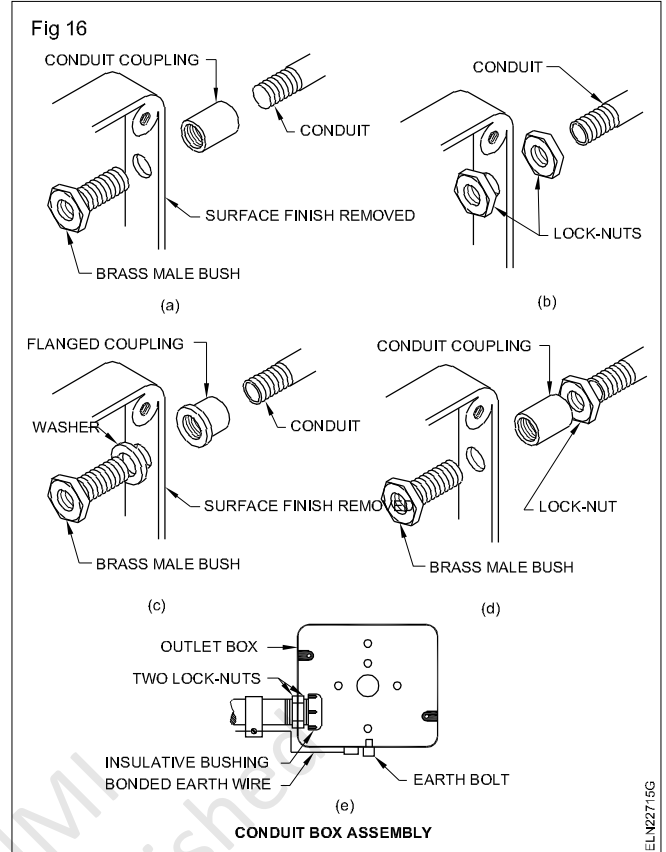

second purpose is to give a proper grip mechanically and make the conduit electrically continuous in the installation.

Conduit nipples (Fig 19) are provided in conduit termination along with couplers and they serve the same purpose as conduit bushes.

Conduit fittings like elbows, bends and Tees: All these fittings are available in two categories.

- Normal
- Inspection type

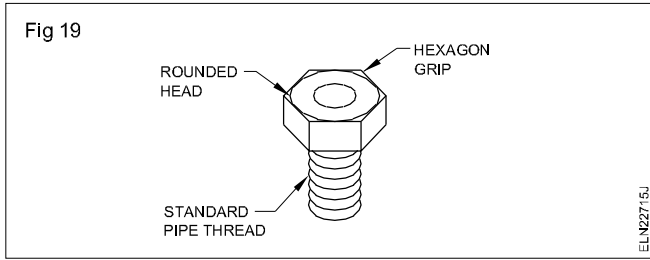

They are made from cast iron.

Elbows are suitable for short bends whereas bends are suitable for long bends. In general where a conduit runs between the wall and the ceiling, elbows are used.

Tees are used in switch-drops and diversions. Various types of these accessories (Fig 20).

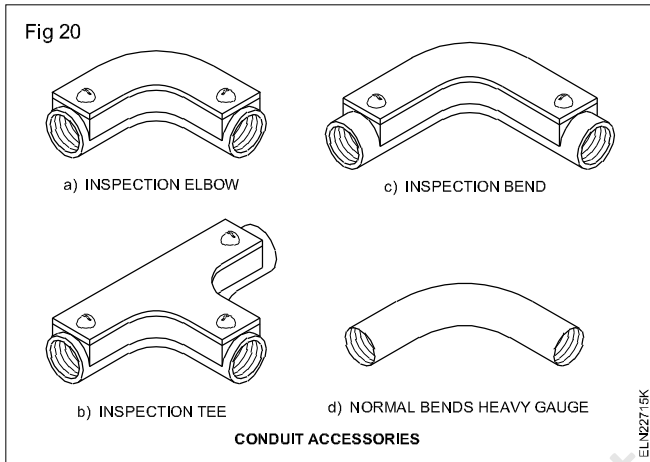

Conduit saddles are used to fasten the conduit on the surface of the walls. These saddles could be used along with any one of the following bases. They are:

- spacers made from sheet metal
- distance piece made from wood or PVC
- hospital piece made from wood or PVC.

Various types of these base fittings along with the saddles are shown in Fig 21.

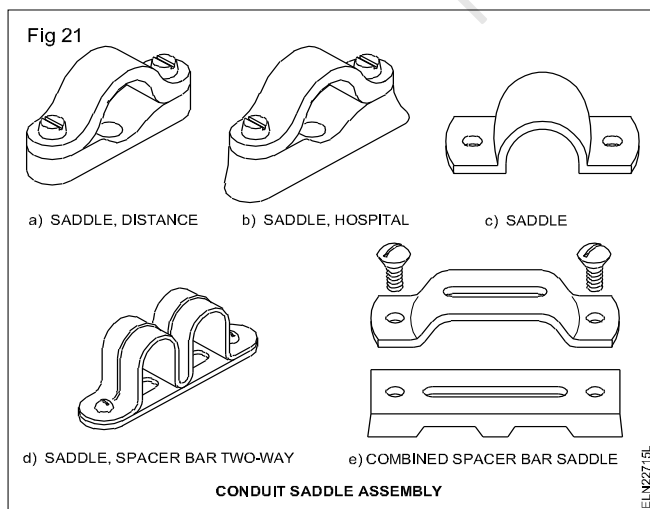

Conduit pipe bending: It is often necessary to set or bend the conduit to enable it to pass over an obstruction

(Fig 22) or to turn a corner which is less or more than 90° (Fig 23). The bending may be a little offset to the line of conduit installation. This can be manipulated by proper bending as required.

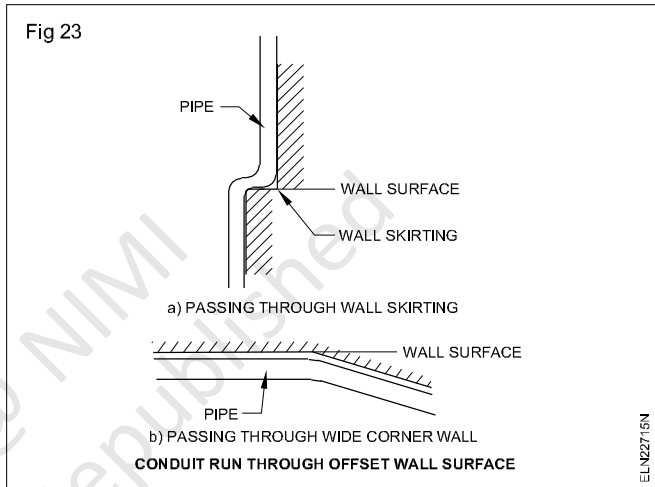
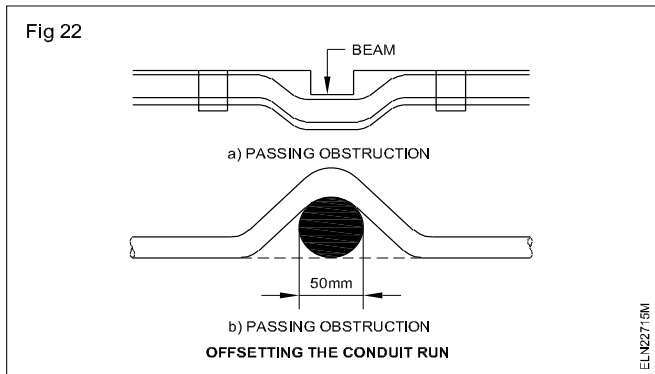

The bending may be done by using a simple bending block or by a hickey or with the help of a bending machine. Further, in concealed conduit wiring, the B.I.S. recommends bending of conduit pipes in preference to the use of bends and elbows.

Using bending block for bending conduit: The bending block (Fig 24) is made preferably with teak wood or strong country wood, and should have holes suitable for the conduit to be bent. Edges are chamfered to avoid kinks in the bent portion of the conduit. Light gauge conduits need to be filled with sand and heated before bending to have smooth bends.

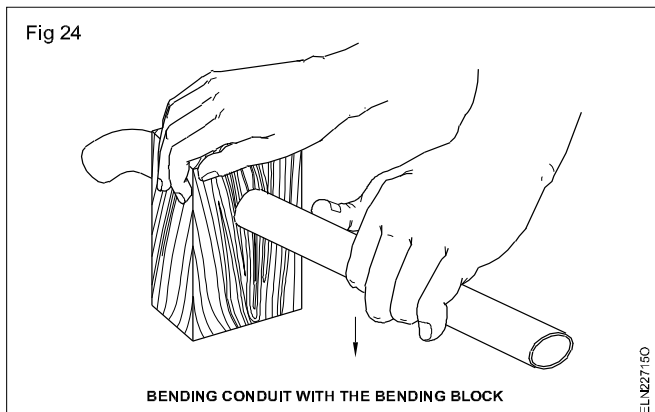

Using hickey for bending conduits: A hickey is a special bending tool (Fig 25) and is made of forged steel or alloy steel. A particular size of pipe requires that size of hickey. Bending of pipes could be performed cold or hot by using a hickey.

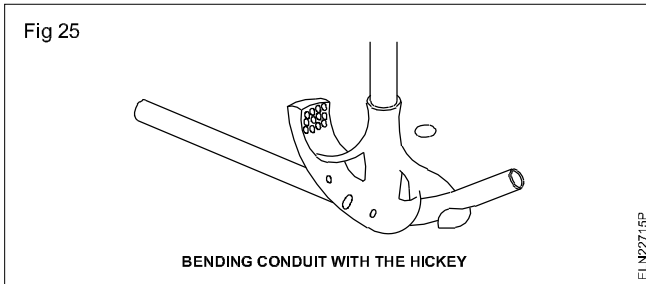

Using bending machine for bending conduit: Various types of bending machines are available in the market. They can either be operated by hand (Fig 26) or by hydraulic pressure. For each size of conduit, the guide and collet need to be changed.

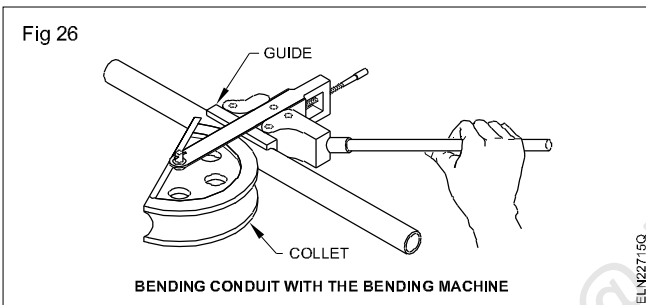

Precautions to be observed while bending

- The pipe used should be mechanically strong to withstand the pressure while bending.
- Poorly seam-welded pipes are not suitable for bending as they may split while bending.
- One of the easy methods of bending is to draw the bending curve on the floor and bend the pipe accordingly.
- When a wooden block is used for bending, chamfer both sides of the hole opening in the block.
- Ensure that the conduit does not twist while bending.
- Use a proper size of hickey according to the dia. of the pipe to be bent.
- While doing manual hot bending do not use wet sand as the steam generated during heating may cause an explosion.

Test board, Extension board and colour code of cables

Objectives: At the end of this lesson you shall be able to

- explain the method of using a test board
- state the general colour codes used in cables.

Test board: A test board is an electric switch board, used for conducting the following tests.

- **Continuity test** (Load connected in series with a lamp)

Example: Testing of fan winding, condition of choke and tube light starter etc.

- **Direct test**

Example : Testing electrical appliances of 1000 watts or lower rating for proper functioning.

Fig 1 source the schematic diagram of a test board with all the outlets and controls. Sockets P₁ and P₂ provide direct, single-phase supply whereas socket P₃ and terminal block T provide a single-phase supply in series with the lamp L₃.

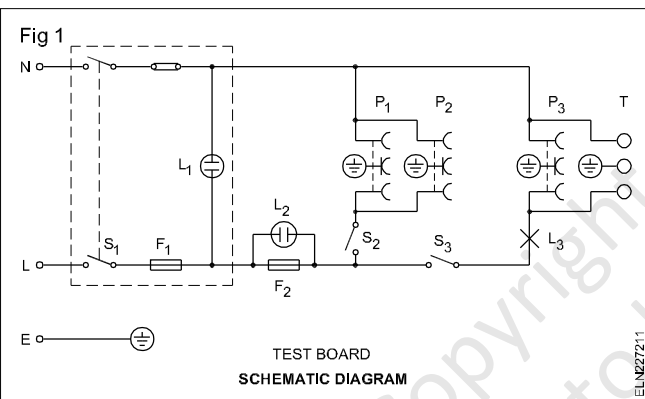

Continuity test: While performing a continuity test, the appliance to be tested is connected to the socket P₃ or to the terminal T which are in series with the lamp L₃ and are controlled by switch S₃. Normally this test is conducted by the electrician to ascertain whether the appliance is open-circuited or short-circuited. A low wattage, appliance when connected, will make the lamp L₃ to burn dim, and a high wattage appliance will make the lamp to burn bright.

According to the brightness of the lamp, the behaviour of the appliance, as well as the wattage of the appliance and the lamp and the condition of the appliance could be judged. 'No light' indicates either open circuit or high resistance in the appliance. In the same way, a choke coil and a starter of a tube light can be checked. (The flickering of the lamp L₃ with the starter indicates that the starter is good.)

Thus the testing board also works as a continuity tester.

Direct testing: By connecting the appliance direct to the socket P₁ or P₂, the performance of the appliance can be verified after repair.

Fuses: If the indicator lamp L₁ does not burn, it indicates no supply. On the other hand, in normal conditions, the indicator lamp L₂ will not burn, and it burns only when the fuse F₂ is open.

Thus the test board is a cheap and handy test set which is easy to use by an electrician to carry out his routine checks in the course of his work.

Colour identification of cables: The colour of the cables indicates their function. Table 1 gives the colour code and the alpha-numeric notation as recommended by N.E.Code.

The rules apply for marking conductors in equipment/ apparatus/installation.

TABLE 1

Alpha-numeric notation and colours

Designation of		Identification by	
		alpha	colour
Supply AC system	Phase 1	L1	Red
	Phase 2	L2	Yellow
	Phase 3	L3	Blue
	Neutral	N	Black
Apparatus AC system	Phase 1	U	Red
	Phase 2	V	Yellow
	Phase 3	W	Blue
	Neutral	N	Black
Supply DC system	Positive	L+	Red
	Negative	L-	Blue
	Mid-wire	M	Black
Supply AC system (Single phase)	Phase	L	Red
	Neutral	N	Black
Protective Earth conductor		PE	Green and yellow
Earth		E	Colour of the bare conductor.

Extension board (Fig 2)

Extension boards are used to operate portable electrical appliances/ machines. It is also used where more number of sockets are required at a time.

Extension boards are available in different shapes with PVC (or) plastic boxes provided with 2 core (or) 3 core cables and moulded plugs. Extension boards are available in 6A and 16A ratings.



Conduit wiring - types of conduits - non-metallic conduits (PVC)

Objectives: At the end of this lesson you shall be able to

- distinguish between the different types of conduits used in wiring
- compare metal and PVC conduit wiring
- state the different types of accessories used in non-metallic conduits wiring.

In general, conduit is defined as a tube or channel, which is the most commonly used in electrical installations. When cables are drawn through the conduit and terminated at the outlet or switch points, the system of wiring is called conduit wiring.

Types of conduits

There are four types of conduits used for wiring.

- Rigid steel conduits
- Rigid non-metallic conduits
- Flexible conduits
- Flexible non-metallic conduits.

Non-metallic conduits

These are made of fibres, asbestos, polyvinyl chloride (PVC), high density polyethylene (HDP) or poly vinyl (PV). Of the above, PVC conduits are popular owing to their high resistance to moisture and chemical atmosphere, high dielectric strength, low weight and low cost. These conduits may be buried in lime, concrete or plaster without harmful effects.

However, light gauge (lower than 1.5 mm wall thickness) PVC pipes are not as strong as metal conduits against mechanical impact. Special PVC pipes which are heavy gauge and high impact resistance are available in the market which can withstand heavy mechanical impact as the thickness of the pipe is more than 2 mm.

There are some PVC heavy gauge conduits having special base material made to withstand temperatures up to 85°C. These PVC conduits are available in 3 m length.

Flexible conduits

Apart from rigid conduits, flexible conduits are also used for protecting cable ends connected to a vibrating machine inter connection between switchgear and distribution boards. In the case of metal flexible conduits, steel strips are spirally wound to form a tube. However, these flexible conduits of any type cannot be relied on as the sole means of earthing due to the manufacturing method as well as material. Hence, earthing conductors should run either externally or internally to the flexible conduit to form the earth connection. Flexible conduit accessories should be of threaded type.

Variation in conduit wiring systems

There are two types of conduit wiring systems as stated below, for either metallic or non-metallic types.

- Surface conduit wiring system done on wall surfaces.
- Concealed (recessed) conduit wiring system done inside the concrete, plaster or wall.

Selection of the type of conduit

Metallic or PVC conduits are equally popular in electrical installations. Selection of the type of conduit depends upon the following criteria.

- Type of location, outdoor or indoor
- Type of atmosphere, dry or damp or explosive or corrosive
- Expected working temperature
- Exposure to physical damage due to mechanical impact
- Allowable weight of conduit runs
- Estimated cost.

A comparison between metal and PVC conduit wirings given in Table 1 will help in choosing the right type of conduit for a specific installation.

Table 1

Comparison between metal and PVC wirings

Metal conduit	PVC conduit
1 Provides good physical protection to cables.	Comparatively poor.
2 Weighs more for a given length.	Lighter.
3 Needs skill and time for installation.	Needs less skill and time.
4 Risk of electric shock due to leakage.	No risk as PVC is an insulator.
5 Good earth continuity available through the pipe itself.	Not possible. Separate earth wire required.
6 Can be used in gas-light and explosive-proof installations.	Not suitable.
7 Not resistant to corrosion, needs protective coating.	Resistant to corrosion.
8 Large ambient temperature range	Suitable for limited temperature range. At temperature above 60°C, the conduit starts melting. At very low temperature the conduit cracks.
9 Fire resistant.	Non-fire-resistant.
10 More costly.	Less costly.

Special precautions with non- metallic conduits

- 1 If the conduits are liable to mechanical damages they should be adequately protected.
- 2 Non-metallic conduits shall not be used for the following applications.

- In concealed/inaccessible places of combustible construction where the ambient temperature exceeds 60°C.
- In places where the ambient temperature is less than 5°C.
- For suspension of fluorescent fittings and other fixtures
- In areas exposed to sunlight.

Non-metallic conduit accessories

Non-metallic conduit fittings and accessories shall be fabricated or moulded to the required shape. They shall be so designed and constructed so that they can be fitted with the corresponding conduit sizes without any adjustment, ensuring ready mechanical protection to the cables.

These fittings and accessories are used for conduit extension, and tappings or to assist pulling conductors. Rigid conduit accessories are normally of grip type only.

Inspection type, non-metallic fittings and accessories are permitted to be used only with surface mounting type wiring. Inspection fittings shall be so constructed that the screws used for fixing the cover do not deform the conduits or damage the insulation of the cables enclosed.

PVC fittings and accessories

Couplers (Fig 1)

Normally push type couplers are used and the conduit shall be pushed right through to the interior of the fittings. Inspection type couplers are used in straight conduit runs to assist in the inspection of the cables.

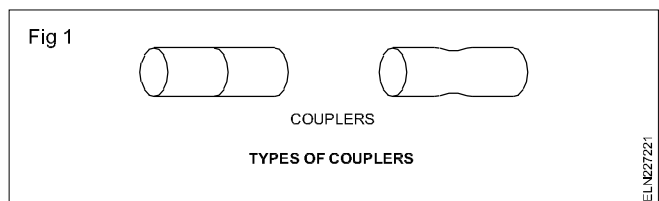

Elbow (Fig 2)

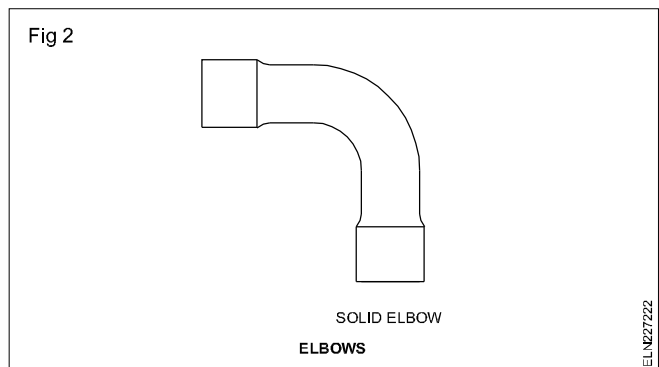

The axis of any elbow shall be a quadrant of a circle plus a straight portion of each end. Elbows are used at sharp ends of nearby walls or roof and wall.

Bends (Fig 3)

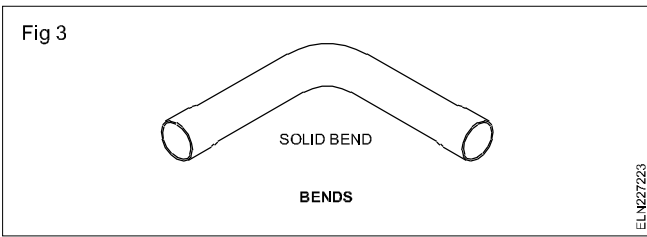

A bend gives a diversion of 90°C in the turn of a conduit, and a normal bend shall be a large sweep. Inspection type bends are used to assist in the inspection at the corners and for drawing cables.

Tees (Fig 4)

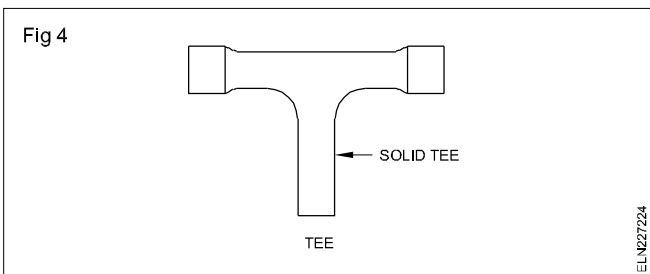

Tees are used to take diversion from the main line either to the switch points or the light points. It may be either an ordinary type or an inspection type. Inspection type tees are used to assist in the inspection in case there is a need.

Boxes

Circular boxes (Fig 5)

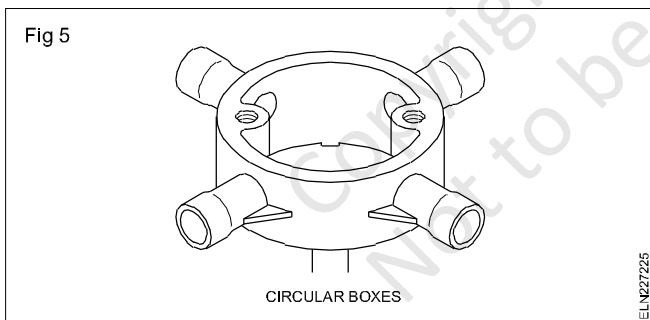

Small circular boxes shall be provided with two machine screws of a diameter not less than 2.8 mm for fixing the covers. Large circular boxes have four machine screws of not less than 4 mm diameter having not less than 10mm threaded portion for fixing the cover.

They are available in a single-way, two-way, three-way and four-way as well as back outlet types which can be used as per necessity in wiring. The minimum depth of junction boxes used in roof slabs shall be 65 mm. The cover of the circular box shall be made of the same material as that of the the box, and have a minimum thickness of 1.6 mm.

Rectangular boxes (Fig 6)

These boxes shall be provided with two machine screws of a diameter not less than 2.8 mm for fixing the cover. They

can be used as a junction box or switch box, for fixing flush type switches. These boxes shall be free from burrs, fins and internal roughness. The minimum thickness of the wall and base of the PVC box should be 2 mm and clear depth of 60 mm.

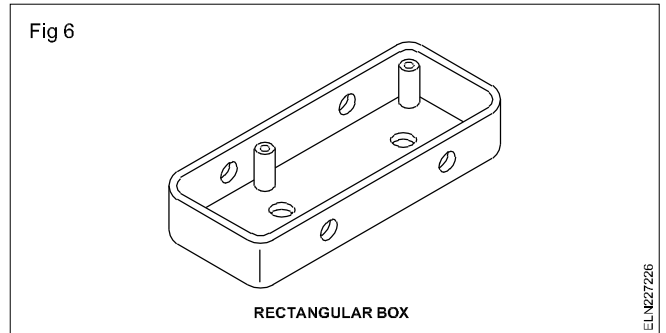

Apart from the above types, various other types are used as junction boxes (Fig 7).

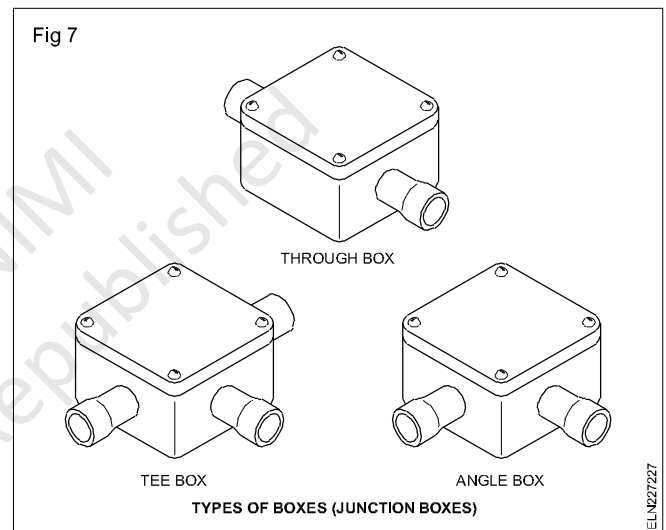

Method of cutting, joining and bending PVC conduit pipes

While doing the conduit wiring, it becomes essential, that the length has to be increased or decreased. Further the conduit is to be bent according to the required situation.

Cutting PVC conduit

A PVC conduit is easily cut by holding at the corner of a bench and using a hacksaw. Any roughness of cut and burrs should be removed with the aid of a knife blade/emery sheet, or sometimes by using a reamer. Before installing the PVC conduit pipe great care should be taken to remove the burrs inside the pipes to avoid damage to the cables during the cable drawing process.

Joining conduit with fittings

The most common jointing procedure uses a PVC solvent adhesive. Before applying the adhesive the inner surface of the accessory and the outer surface of the PVC pipe shall be cleaned with emery sheet to have a better grip. The adhesive should be applied to the receiving portion of the

conduit fitting, and the conduit twisted into it to ensure a total coverage.

Generally, the joint is solid enough for use after two minutes although complete adhesion takes several hours. In order to ensure a sound joint, the tube and fittings must be clean and free from dust and oil.

Where expansion is likely and adjustments become necessary a mastic adhesive should be used. This is a flexible adhesive which makes a weatherproof joint, ideal for surface installations and in conditions of wide temperature variation. It is also advisable to use the mastic adhesive where there are straight runs on the surface exceeding 8 metres in length.

Conduit fittings should be best avoided, as far as possible, on outdoor systems.

Bends in conduit

All bends in the non-metallic system shall be formed either by bending the pipes by proper heating or by inserting suitable accessories such as bends elbows or similar fittings. Solid type fittings shall be used for recessed wiring. Solid type/inspection type of fittings shall be used for surface conduit wiring.

The minimum bending radius of conduits shall be 7.5 cm. Care should be taken while bending the pipes to ensure that conduit pipes are not damaged or cracked and the internal diameter is not effectively reduced.

In recessed conduit wiring, conduit bending, other than at the ends, shall be made by bending the pipes to the required angle and clamping at short intervals. In the case of conduits laid in the roof slab, it can be clamped or tied to steel reinforcement bars with suitable metallic clamps.

In the case of conduits recessed on walls, the chasis shall be made in the required shape and conduit fixed in the groove with suitable clamps. In the case of bending for surface conduit system, bending can be done either at cold state or by proper heating.

Cold bending PVC conduit pipes

PVC conduits not exceeding 25 mm diameter can be bent cold by using a spring. The bend is then made either with the hands or across the knee (Fig 8). In order to achieve the angle required the original bend should be made at twice the angle required and the tube allowed to return to the correct angle.

Under no circumstances should an attempt be made to force the bend back with the spring if it is twisted in an anticlockwise direction. This reduces the diameter of the spring, making it for easy withdrawal.

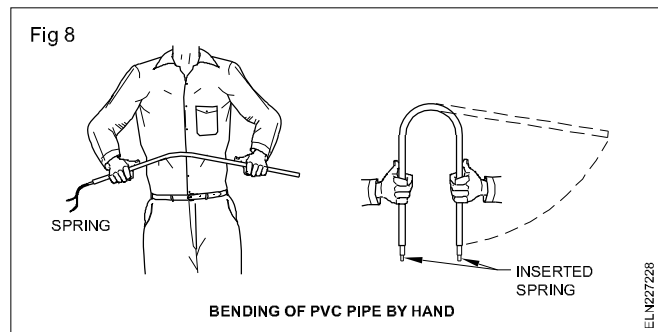

Bending PVC conduit in cold weather

In cold weather it may become necessary to warm the conduit slightly at the point where the bend is required. One of the simplest ways to do this is to rub the conduit with the hand or a cloth. The PVC will retain the heat created long enough for the bend to be made. In order that the bend is maintained at the correct angle, the conduit should be saddled as quickly as possible.

Bending of conduit by heating

The piece of conduit to be bent is first cut and inspected for any sharp edges or burrs left out. In such cases it shall be made smooth by using suitable emery sheet. The conduit is then filled with river sand. The ends are sealed with suitable dummy covers. The portion where the bend is to be made shall be heated uniformly (Fig 9a) to a temperature below its melting point.

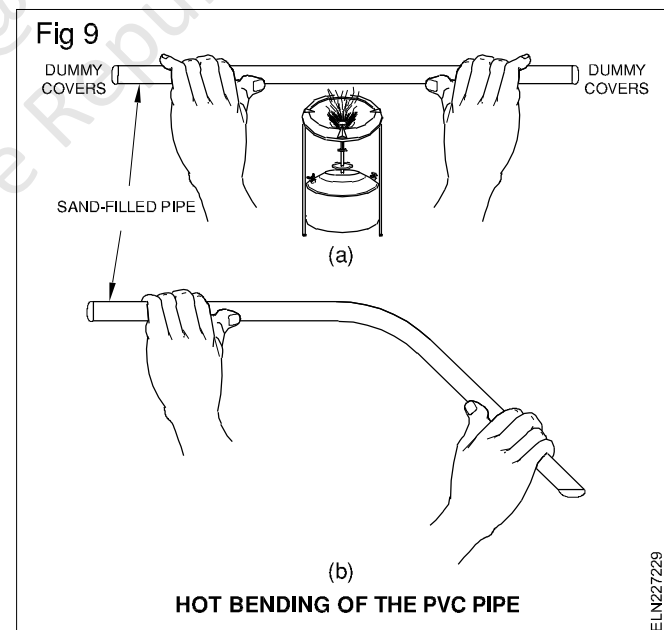

Then bend the required angle is made by holding both sides, with sufficient gap from the heated portion to avoid burning of hands, and applying uniform pressure (Fig 9b). Care shall be taken to avoid kinks on the conduits while bending.

Selection of conduit sizes and general regulations

Objectives: At the end of this lesson you shall be able to

- state the method of selection of a suitable size of conduit for a specific number and size of cables.

In PVC conduit wiring the first step is to select the correct size of conduit. The conduit size is determined by the size of cables and the number of cables to be drawn in a particular section. This information can be obtained from the wiring layout and the wiring diagram.

Selection of conduit size

A non-metallic conduit pipe, used in wiring, should have a minimum size of 20 mm in diameter. Where a large number of conductors are to be drawn, the size of the diameter depends on the size of the conductor and the number of conductors. Table 1 gives details of the numbers and the sizes of conductors that can be drawn in each size of a non-metallic conduit.

Example

For selection of a PVC conduit

When 2.5 sq mm 650 V grade single core cables of six numbers are to be drawn in a single run, we can use 25 mm non-metallic conduit as per the table.

When 6 sq mm. 650 V single core 6 cables are to be drawn in a single pipe we can use 32 mm PVC pipe. The following are the maximum permissible number of 650/1100V volts grade single core cables that may be drawn into rigid non-metallic conduits (Table 1).

TABLE 1

Maximum number of PVC insulated 650 V/1100 V grade aluminium/copper conductor cable drawing through conduits conforming to IS: 694-1990.												
Nominal Cross-sectional area of conductor in sq.mm	20 mm		25 mm		32 mm		38 mm		51 mm		70 mm	
	S*	B*	S	B	S	B	S	B	S	B	S	B
1.50	5	4	10	8	18	12	–	–	–	–	–	–
2.50	5	3	8	6	12	10	–	–	–	–	–	–
4	3	2	6	5	10	8	–	–	–	–	–	–
6	2	–	5	4	8	7	–	–	–	–	–	–
10	2	–	4	3	6	5	8	6	–	–	–	–
16	–	–	2	2	3	3	6	5	10	7	12	8
25	–	–	–	–	3	2	5	3	8	6	9	7
35	–	–	–	–	–	–	3	2	6	5	8	6
50	–	–	–	–	–	–	–	–	5	3	6	5
70	–	–	–	–	–	–	–	–	4	3	5	4

* The above table shows the maximum capacity of conduits for a simultaneous drawing in of cables.

* The columns headed 'S' apply to runs of conduits which have a distance not exceeding 4.25 m between draw in boxes and which do not deflect from the straight by an angle of more than 15 degrees. The columns headed 'B' apply to runs of conduit which deflect from the straight by an angle of more than 15 degrees.

* Conduit sizes are the nominal external diameters.

PVC Channel (casing and capping) wiring

Objectives: At the end of this lesson you shall be able to

- state the use limitation and rules of channel wiring system
- select the channel size according to size and number of cables from the chart
- explain the method of fabricating neutral, bend, and junction in PVC channel .

Introduction : Channel (Casing and Capping) wiring is a system of wiring in which PVC/metallic channels with covers are used for drawing wires. This system of wiring is suitable for indoor surface wiring works. This system is adopted to give a good appearance and for extension of existing wiring installation. PVC insulated cables are generally used for wiring in casing and capping system. This is otherwise called 'wireways'.

The channel and top cover shall be of the same material either PVC or anodised aluminium. The casing is square or rectangular in shape. The capping shall be slide in type with double grooving in the case of PVC wire ways. Plain type capping are used for metallic wireways.

The only disadvantage in a channel wiring is that it is inflammable and risk of fire.

Channel (casing & capping) wireways should not be used.

In residential buildings or such buildings where there is a risk of tampering where ambient temperature exceeds 60°C or less than 5°C in areas exposed to sunlight.

Dimensions : The sizes of channel, the maximum number of wires which can be drawn in each size are given in the table 1 below.

The thickness of channel should be 1.2mm ± 0.1mm.

TABLE 1

Nominal cross sectional area of conductor in sq.mm	10/15mm x 10mm size channel	20mm x 10mm size channel	25mm x 10mm size channel	30mm x 10mm size channel	40mm x 20mm size channel	50mm x 20mm size channel
	No. of wires	No. of wires	No. of wires	No. of wires	No. of wires	No. of wires
1.5	3	5	6	8	12	18
2.5	2	4	5	6	9	15
4	2	3	4	5	8	12
6	-	2	3	4	6	9
10	-	1	2	3	5	8
16	-	-	1	2	4	6
25	-	-	-	1	3	5
35	-	-	-	-	2	4
50	-	-	-	-	1	3
70	-	-	-	-	1	2

Precautions

- 1 Neutral (Negative) cables should be carried in top channel and phase (Positive) in the bottom channel.
- 2 Crossing of cables between phase (Positive) and neutral (Negative) should be avoided.
- 3 Porcelain or PVC pipe should be used for crossing the cables through the walls.

Installation of PVC channel : The channel should be fixed to wall/ceiling with flat headed screws and rawplugs. These screws shall be fixed at an interval of 60cm. On either side of joints this distance shall not exceed 15cm from the end point. Channel under steel joints shall be fixed with MS clips of not less than 1.2mm (18SWG) thickness and width not less than 19mm.

Floor/Wall crossings : When conductor pass through floors/wall the same should be carried in a steel conduit/ PVC conduits properly bushed at both ends. The conduits shall be carried 20cm above floor level and 2.5cm below ceiling level and properly terminated into the channel.

Joints in PVC/Metal channel : As far as possible wireways in straight runs should be single piece. All joints shall be scarfed or cut diagonally in longitudinal section. The section ends shall be filed smoothly but joined without any gap. Care shall be taken to see that the joints in PVC cover does not overlap those channel.

Joints shall also be done using standard accessories like elbows, tees, 3 ways/4 ways junction box etc of high grade PVC/Aluminium alloy. In PVC channel separate channel

cover for joint, elbows, tees, cross etc are available. These can be fixed after fixing the channel to give a good appearance. The radius of curvature of the cables inside a bend should be more than 6 times its over all diameter.

In the case of PVC channel, making joints is comparatively easy. Mark the joints by placing the two pieces in required angle. Identify the position to be cut and remove on each piece. Cut through the lines and file the edges to get gapless joint.

Fabricating a right-angled vertical bend

- 1 Mark out the position of bend of all sides as shown in Fig 1. the width 'Y' must be made equal to the diagonal length 'Y' to be cut.
- 2 Drill small holes in corners at point of bend to stop channel folding (Fig 1).

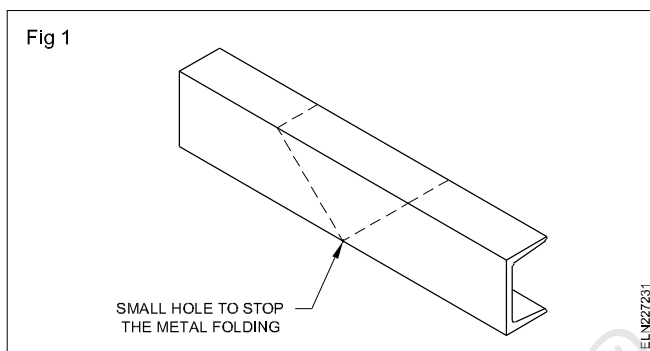

- 3 Place wood blocks inside trunking for support. Cut sides of trunking (Fig 2).

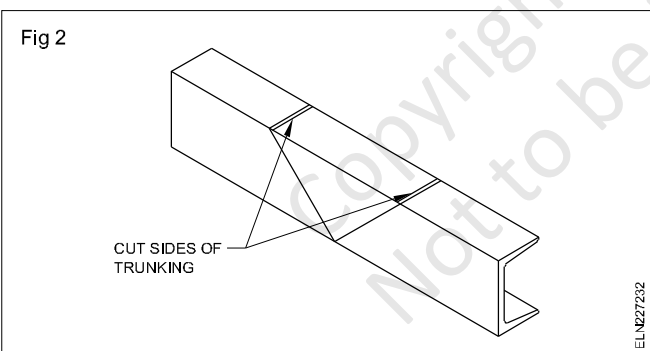

- 4 Cut, file and break-off waste (Fig 3).

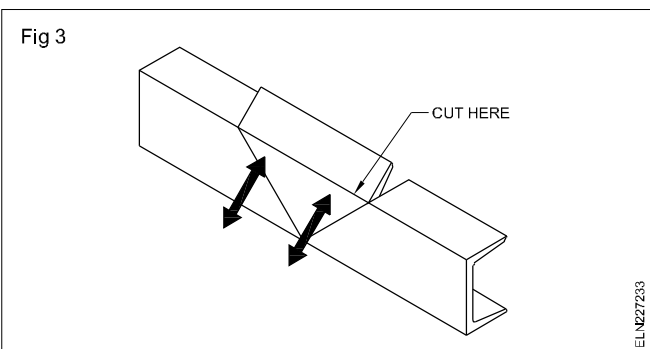

- 5 File all the edges smooth in order to bend to shape (Fig 4).

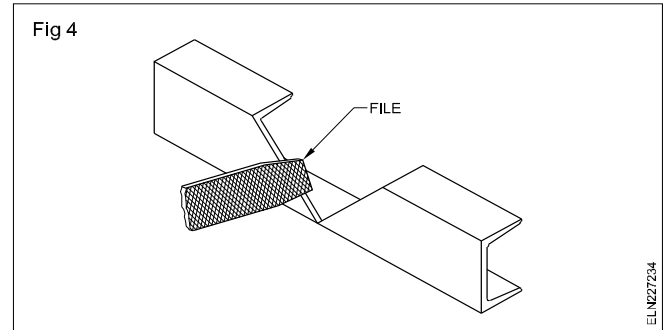

- 6 Make 'L' plates out of PVC scrap (Fig 5).

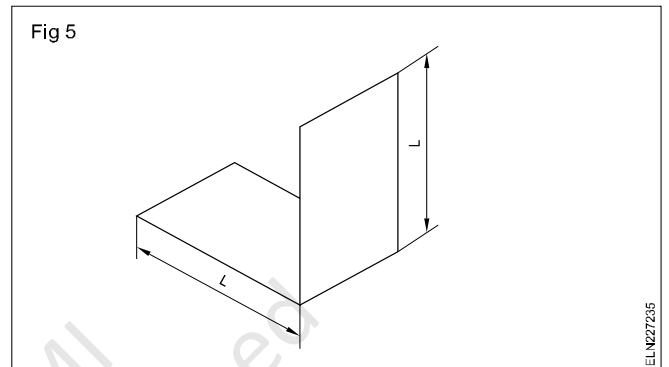

- 7 Make and secure assembly with 'L' plates and paste it with suitable adhesive (Fig 6).

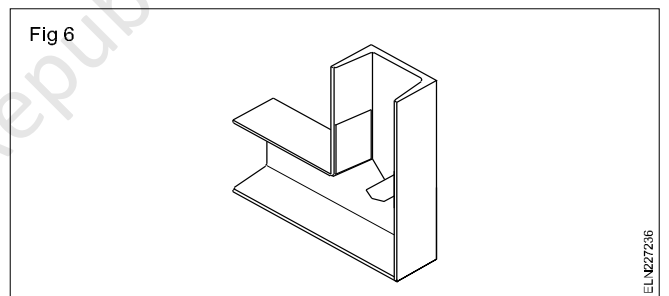

Fabricating 90° bend

- 1 Mark out the position of bend (Fig 7a & b).

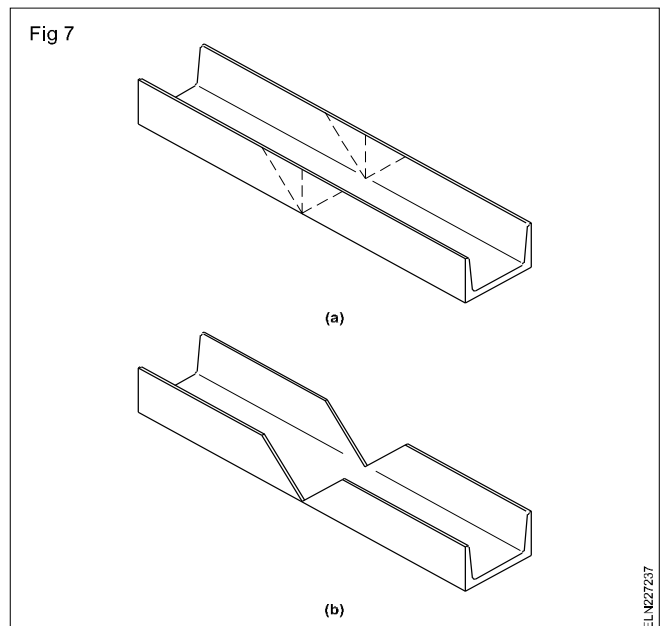

- Place wood blocks in trunking for support and make cuts with hacksaw.
- Remove sections and file smoothly.
- Bend shape and adjust the fit as required (Fig 8a, b & c).
- Make fish plates from PVC scrap (Fig 8b).
- Make and secure the assembly with fish plate (Fig 8).

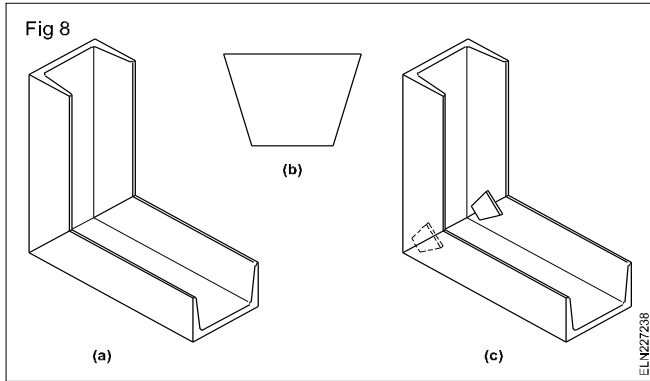

Fabricating a Tee junction

- Mark out the position of tee using another piece of trunking to gauge width
- Cut out the space for the tee (Fig 9a). Blocks of wood should be used to support section being cut.
- In another piece cut away the section (Fig 9b) to form two legs (Fig 9c).

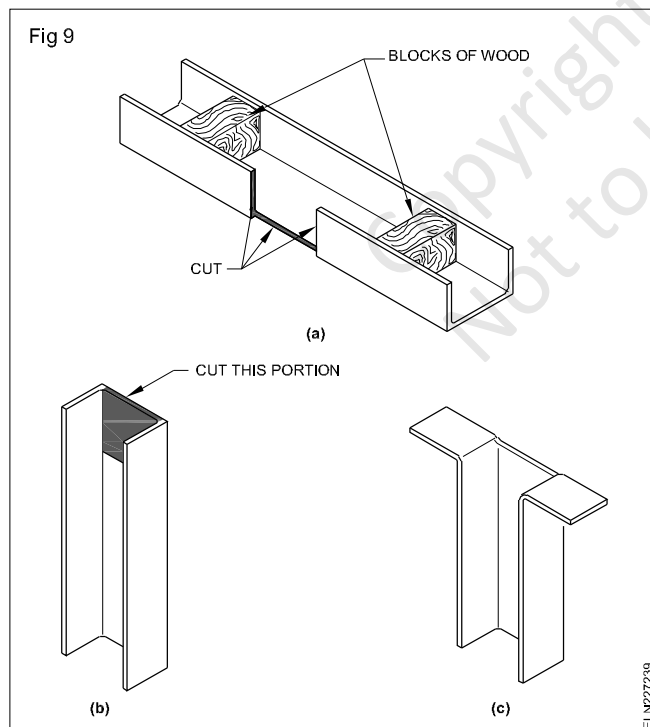

- File edges smooth and remove burrs. Check fit and adjust as necessary.
- Make, assemble and secure the Tee junction using suitable adhesive (Fig 10).

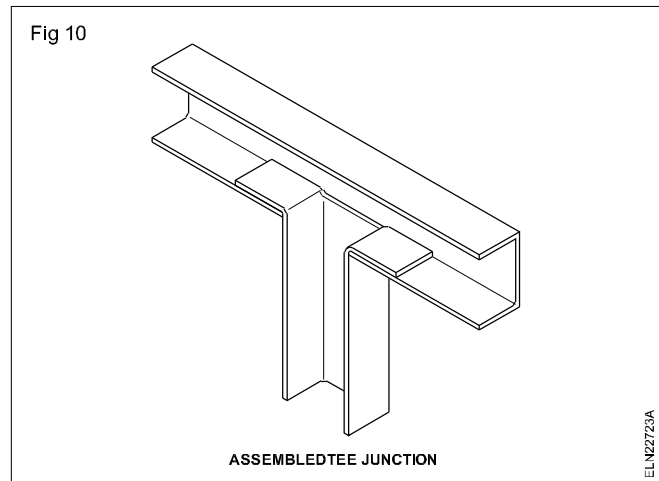

Fabricating a cross junction

- Mark the position of first set (Fig 11a).
- Place blocks of wood in trunking for support and make cuts with hacksaw.
- Remove section of trunking and file the edges.
- Take another two pieces and cut away the section (Fig 11b) to form two legs (11c).

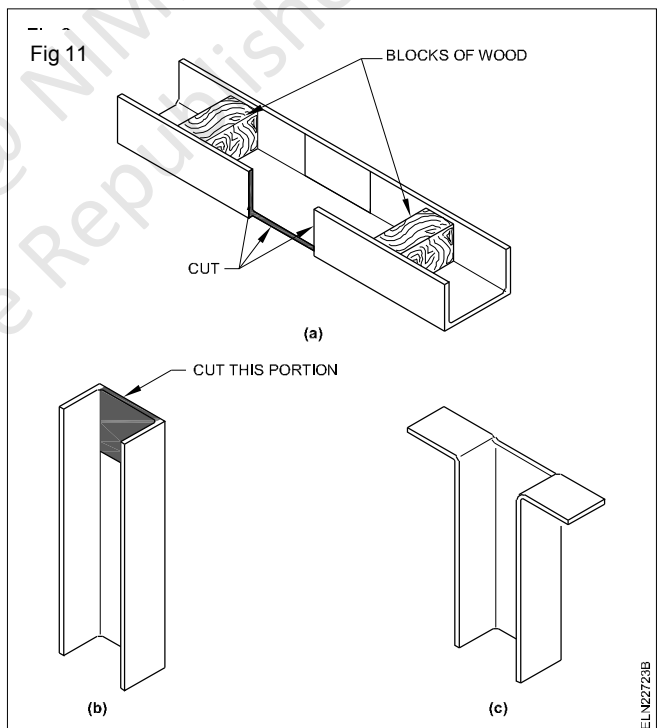

- Make, assemble and secure the cross junction using suitable adhesive (Fig 12).

Installation of cables : Cables carrying the direct current or alternate current shall always be bunched separately so that the outgoing and return cables are drawn in the same channel. Clamps shall be provided to hold the wires inside the channel at suitable intervals, so at the time of opening of the cover of channel, the wires do not fall out.

Fig 12

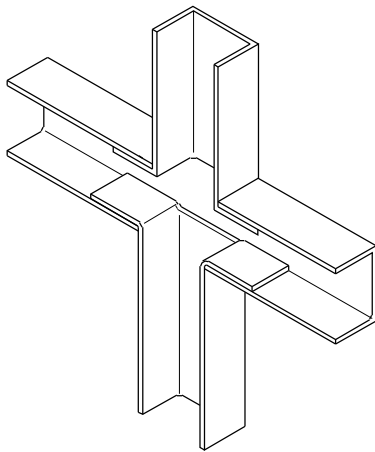

ASSEMBLED CROSS JUNCTION

ELN2723C

Attachment of cover : Cover should be attached to channel in individual sections after drawing all wires inside. No screws or nails shall be used for fixing PVC capping (cover) to the casing (channel). The capping (cover) should be slid in through the grooves. Metallic capping (cover) shall be fixed by using cadmium plated screws in a staggered manner with axial spacing not exceeding 30cm.

Earth continuity conductor : Earth continuity conductor shall be drawn inside the casing and capping (channel) for earthing of all metallic boxes of the installation as well as for connecting to earthpin of the socket.

In case of metallic casing and capping channel, there shall be a metallic link between adjacent casing with screw connections, and also connections from end channel (casing) to earth terminal of metallic boxes/outlets.

Power wiring

Objectives: At the end of this lesson you shall be able to

- state the power, control, communication and entertainment wiring
- state the necessity of various wiring.

A panel wiring diagram usually gives information about the relative position and arrangement of devices and terminals of the devices to help in installing or servicing the device.

Generally all the control panel / commercial / industrial wiring invariably consists of two sections viz control wiring and power wiring.

Fig 1 shows the typical layout diagram of a motor wiring. The control panel consisting of all the control and protective devices installed near to the power source and the load like, furnace, compressor etc, are installed away from the power source / panel boards.

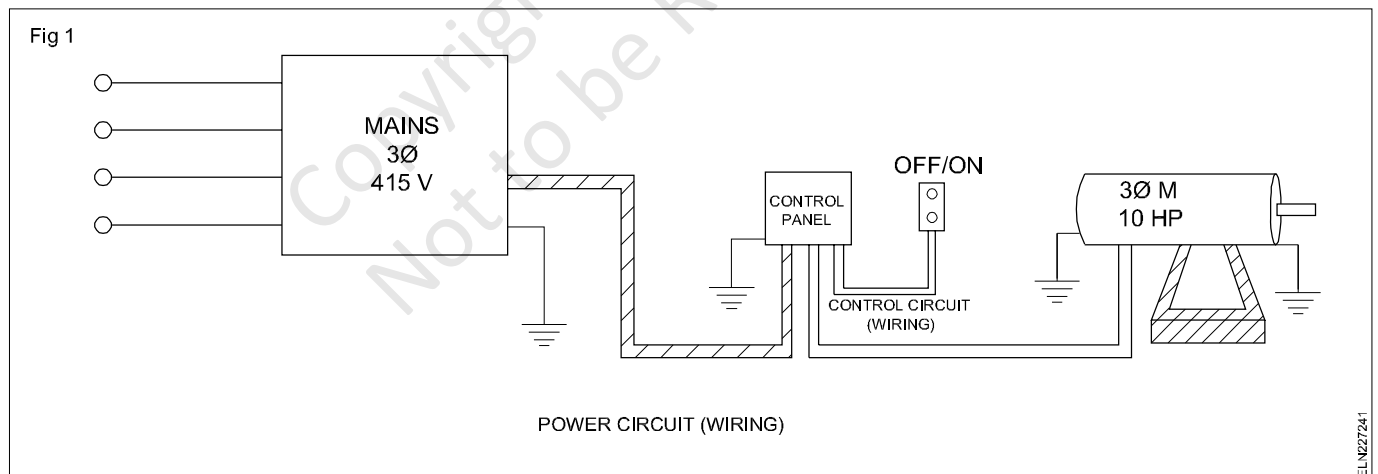

Power wiring is a high current carrying circuit which is wired to connect / disconnect the load like motors/ furnace through the protective devices like OLR and fuses etc..

Power wiring has to be done as per the guideline and rules specified in IE rules. The cable size depends on the load current and it varies according to the load.

The power and control cable should not be run into single conduit. As the current radiation influences the control cable, a separate conduit to be provided for control and power cables.

Control wiring

Control wiring is a circuit which is wired to communicate the commands and other information between control devices and lighting.

Control wiring enables the control circuit for various control purpose. In a motor control unit the control circuit is wired and kept near to motor. In other system such as fire alarm, fire detector etc. The control circuit is wired separately with low current carrying conductors and drawn separately for easy maintenance.

Fire alarm

The purpose of fire alarm system is to provide an immediate alarm in case of any fire and to prevent loss of life, also to secure the immediate attention of fire fighting staff.

Fire detectors

The three principal fire detection method involve sensing the heat, presence of flame or smoke. The third method identifies the pre - fire condition that is a flammable gas detector, which is technically not a fire detector and its use is limited to places where flammable gases are likely to be present.

I Heat detector

The three basic operating principles for heat detection are:

- a Fusion detector (melting of a metal)
- b Thermal expansion detector
- c Electrical sensing

II Smoke detectors

There are three types of smoke detectors namely

- 1 Ionisation detector
- 2 Light - scattering smoke detector
- 3 Obscuration smoke detector.

III Flammable gas detector

A flammable gas detector is designed to measure the amount of flammable gas in the atmosphere. The gas mixture is drawn over a catalytic surface where oxidation i.e. combustion takes place. The combustion causes a rise in temperature of the surface which is measured by a decrease in its electrical resistance. The instruments are calibrated by considering pentane or heptane as reference gas. The readings are displayed in terms of percentage of lower explosive limit.

Control panel for fire alarm system

The control panel is the heart of the system through which the fire alarm system is monitored and alarm is initiated if any indication/signal is conveyed to the panel.

The working of the fire alarm system should be checked once in a month regularly.

The features of the control panel are the power supply, battery charging unit and control card.

Communication wiring

It is type of wiring which is used to transmit the voice, data, images and video etc to the desired places.

Some of examples are

- Telephone wiring
- Internet / LAN network wiring
- Cable TV and other entertainment wiring
- Data and security services wiring
- Telex/ Fax machines wiring

Faster and more reliable than ordinary phone wiring, low-cost, high-tech copper wiring should serve every room in the modern home. Its is required to carry voice, data and other services from where they enter the house to every room, and from any one room to any other.

Necessity of communication wiring

Unshielded twisted pair (UTP) copper information wiring often called structured wiring is used today for offices, schools and factories to provide local area networks (LANs), which allow computers to talk to one another and to receive and send Internet and high-speed computer data outside the facility.

Educated homebuyers-and homebuilders realize it is better to use the most advanced wiring technology up front, when installation is economical.

It's better to anticipate the homeowner's future needs by wiring the house with a state-of-the-art system while it is being built, and at the same time equip yourself with a powerful marketing tool.

The phone wiring of the past, often referred to as quad wiring because it has four copper wires, is now obsolete. Cat 5 or higher speed wiring has four twisted wire pairs, or eight wires.

Copper UTP Wiring

Copper UTP wiring contains eight color-coded conductors (four twisted pairs of copper wires). It offers greatly increased bandwidth compared with old-fashioned quad wiring.

The cable is small (roughly 3/16 inch in diameter), inexpensive and easy to pull, although it must be handled with care.

Advantages

Modern copper UTP wiring offers the following advantages:

Diversity

The Internet and computer communications, as well as ordinary phone signals, can be carried throughout the home on modern, inexpensive, high-speed, UTP cables. (To service a large number of TV channels, it is recommended to also run high-quality coaxial cable, such as quad-shielded RG-6.)

More phone numbers

Several phone numbers can be made available throughout the house. Actually, voice service requires very little bandwidth, and the addition of separate numbers is almost trivial.

Bandwidth

Bandwidth correlates with speed, and these bandwidths are many orders of magnitude greater than the bandwidth required for a "modern" 56 kbps (kilobits per second) modem.

New Services

The Internet is now available at high speed to many homes, but homebuyers are not able to take full advantage of it, if their wiring is inadequate. One high-capacity technology now being offered by local phone companies is DSL (digital subscriber line). And cable modems are being offered by cable TV companies that bring in the Internet on the same coaxial cable carrying the TV signals.

Fig 1 is a simplified plan of a small, two-bedroom, single-story house. Note that all the wiring radiates from a single distribution device the star pattern and there are multiple outlets in each major room, including the kitchen and the porch.

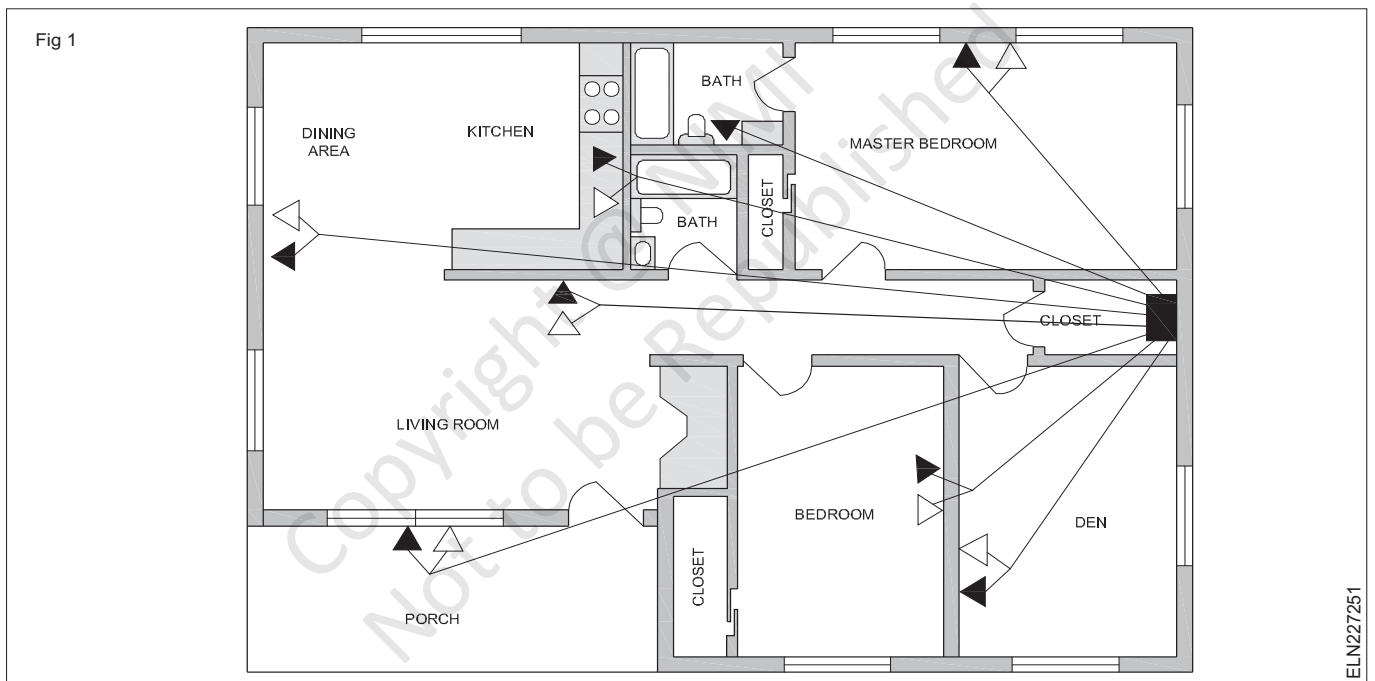

Use 8-Pin Modular (RJ-45) Jacks (Fig 2)

These devices provide connection points for all eight of the wires contained in the four twisted pairs.

Fig 2 (below) shows a wall outlet with two such jacks.

All connecting devices, central distribution device, plugs on the ends of cables, outlets, etc.-should be rated for the cable used.

Finally, the finished installation should be thoroughly tested.

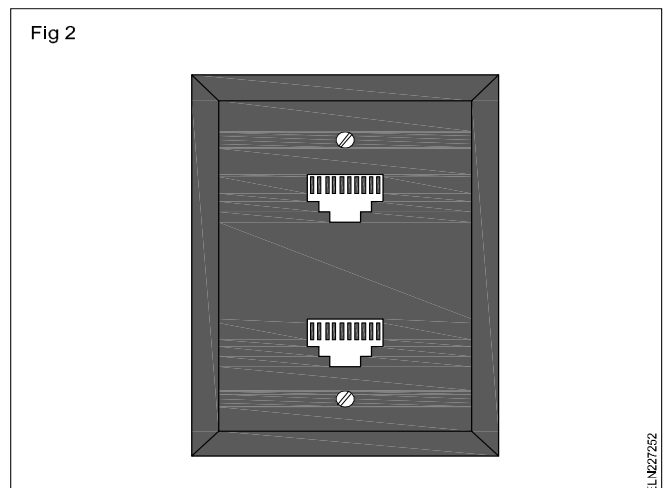

Video Cables

Although the industry is working toward an all-UTP solution for wiring residences, at this time it is prudent to also include conventional coaxial cable for video distribution, particularly cable TV. This is because it is difficult to predict whether many channels well over 100, for example—may become a reality in the near future, some channels of which will be the more bandwidth-consuming high-definition television (HDTV).

If coax is installed, quad-shielded RG-6 coax, with an all-copper center conductor, should be used for superior performance. (Copper-plated steel center conductors are also available, providing additional stiffness, but are unable to handle low-frequency currents used to power some devices.) A lesser grade, RG-59, should not be used.

Entertainment wiring

It is a type of wiring which is mainly used for entertainment or relaxation purpose. Example Home theatre wiring.

The nature and quality of wiring will not only determine the level of safety in home theatre room, but equally important, will have a noticeable impact on the video and sound quality of your system components.

Home Theatre Wiring Basics: Safety, planning, budgeting

When it comes to home theatre wiring, the guiding principle is...

- Do it safe
- Do it once
- Do it right

Safety: This is a most important aspect in any installation. Do not save on the wiring by using sub-standard cables.

With in-wall installations, Specially certified wires (UL-rated CL3 wires) should be used that comply with national standards for resistance to fire, chemicals, abrasion, and temperature extremes.

Planning: Planning is the key to future proofing the installation while avoiding costly alterations later on.

AV (Audio Video) equipment and speaker placement the room lighting requirements, networking, possible future additions, etc. are to be taken care of these will determine the quantity and placement of the various audio/video points in the room as well as the electrical needs for home theatre installation.

Finally, when it comes to estimating the required cable lengths, do not just calculate the linear lengths to complete your cable runs; allow for at least 20% extra to cover for possible errors and slack for terminations.

Budgeting: The wiring requirements during planning stage will determine the budget necessary for your home theater wiring project.

Home Theatre Speaker Wiring

Many fail to realize that home theatre wiring can have a noticeable impact on speaker performance. The greatest speakers will not sound their best with the use of inappropriate speaker wires or an incorrect wiring installation. In particular, selecting the correct speaker wire thickness is essential for the best speaker performance.

At the same time, keep in mind that some speaker manufacturers use non-standard connectors with their speakers; in these circumstances, use of optional third-part speaker wire and connectors may not always be an option unless you take the extreme route of splice your wiring.

Speaker Wire Size

Selecting the correct thickness for your home theater wiring is important as it affects the speakers' performance; it will impact the speakers' ability to deliver the explosive effects in home theatre sound.

The thickness of a wire conductive copper part is identified by its Wire Gauge, normally expressed either in AWG (American Wire Gauge) or SWG (British Standard Wire Gauge)

Single Room Installation

The thicker wire will help bring out fine musical detail in quality music systems, as well as deliver the explosive effects of surround sound.

In those situations where long speaker wire runs cannot be avoided, thicker wire helps reduce the overall resistance, and therefore amplifier load - leading to lower operating temperatures. This will result in improved sound quality and long-term stability.

After setting up a modestly priced home-theatre-in-a-box package, do not go for the more expensive thicker wire unless you plan an upgrade sometime in the future; using of gauge 16 speaker wire should suffice in this case.

Multi-Room Wiring

In a multi-room installation, long home theatre wire runs are inevitable; The suggested wire gauge to use in home theatre wiring is given below:

Distance between speaker and amplifier	Speaker Wire Gauge
Less than 50 feet	16
50 to 100 feet	14
100 to 150 feet	12
more than 150 feet	10

The 'length factor' is not the only issue to consider when determining the wire gauge to use. The speaker impedance should also be taken into account.

Connection Basics

Speakers and amplifiers/receivers normally come equipped with one of two types of connectors - spring terminals or binding post connectors.

Each speaker connection have two such terminals marked (+) and (-) to help you distinguish the two leads. Maintaining correct polarity all along your home theater wiring is important. For this reason, speaker wire and terminals are normally color coded black for the -ve terminal and red for +ve side.

Spring terminals will only accept pin connectors or tinned base wire ends. Instead, binding posts accept many types of connection, including pin, banana plug or spade.

Guidelines for Home theatre wiring & installation

- Do not run home theatre cables in close proximity or parallel to other electrical lines, nor run your wiring around power supplies as these can lead to interference issues with both your audio and video system components.
- Avoid splicing wiring at all cost, as it leads to a lowering in performance. In addition, always use direct speaker wire runs straight from amplifier to each speaker. This is the normal way of wiring the sound in the home theatre but in the case of a multi-room audio installation, some may simply skip on this and splice the speaker cable along the way. Doing so, may not only lead to a detrimental effect but equally important, makes fault tracing even more difficult later should problems arise.
- Leave extra length at each end of the cable runs. And if home theatre wiring is part of a renovation project, it is also advisable to cover the extra cable lengths and termination/junction boxes. The plastering/painting process that follows can be really messy..

Special wiring circuits - Tunnel, corridor, godown and hostel wiring

Objectives: At the end of this lesson you shall be able to

- state the difference between godown, tunnel and corridor, bank/hostel wirings
- draw the tunnel lighting / corridor / bank / hostel circuits
- prepare the mode chart for the above circuits.

Staircase wiring: In wiring one lamp controlled with one switch in a simple wiring circuit to begin with. However, one lamp controlled with two switches from two different places, known as staircase wiring in the very basic wiring. Fig 1 shows such a wiring where two double pole switches are used to control one lamp individually.

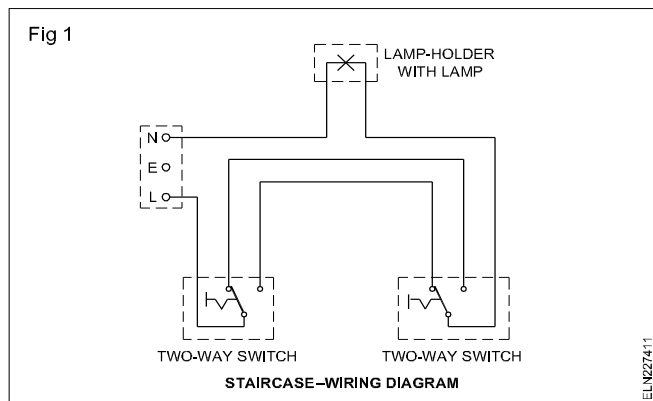

In the case of godown wiring we have seen that as you move inside the godown, you can switch on a lamp ahead of you while the light behind you is put off. The same process in the reverse order takes place while moving out of the godown.

But one light will not be sufficient to give enough illumination in the case of tunnels where darkness is more. Hence, the wiring circuit for a tunnel needs at least two lights to be 'ON' at a time while a person moves inside a tunnel and goes out.

Whereas in the case of corridor wiring the corridor may have a number of rooms occupied by different persons. When one moves toward his room, he needs a forward light to do so. The moment he finds the room and opens it, he may not need the corridor light. Then there should be an arrangement to switch off the light left behind the forward moving person and at the same time there should be a provision to switch off the light in front of his room. Such an arrangement is incorporated in corridor wiring.

On the other hand in bank/jail/hostel, there may be a number of lights having individual controls. There should be a provision for the security staff/warden to switch ON all the lights where they are all OFF. Such a provision is incorporated in the bank / jail / hostel wiring.

Tunnel lighting circuit (Fig 2)

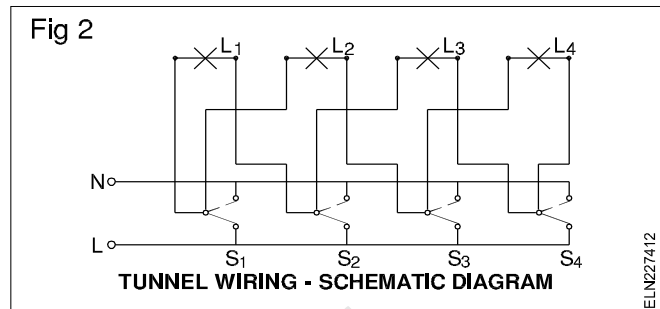

In tunnel wiring a person walking along the tunnel can successively light behind two lamps ahead and put off a lamp behind with one switch.

All switches are two-way switches.

Caution: This circuit is not in accordance with IE rules as the phase and neutral come in the same switch. So care should be taken while connecting the wires.

The mode of operation of the switches and the consequent lighting position are shown below.

Mode chart for tunnel wiring

SWITCHES				LIGHTS			
S ₁	S ₂	S ₃	S ₄	L ₁	L ₂	L ₃	L ₄
✓	✗	✗	✗	✓	✓	✗	✗
✓	✓	✗	✗	✗	✓	✓	✗
✓	✓	✓	✗	✗	✗	✓	✓
✓	✓	✓	✓	✗	✗	✗	✗

MODE CHART FOR TUNNEL WIRING

Corridor wiring (Fig 3)

In this circuit, operating the first switch in one set makes the first light to switch on while operating the 2nd switch in the first set switches off the first light. This sequence goes on as explained in the mode chart.

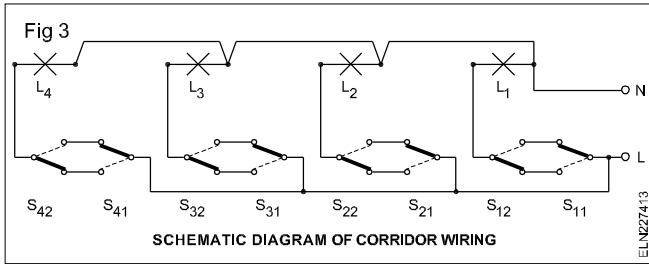

While coming back from the godown when the person switches off the light 4, then the light 3 will be on and give light for his return movement. When he leaves the godown all the lights could be switched 'off' by operating switch S_1 .

The following chart gives the mode of operation of the switches and lights. Trainees are advised to make the return mode chart.

Mode chart for godown wiring

Switches				Lights			
S_1	S_2	S_3	S_4	L_1	L_2	L_3	L_4
ON	OFF	OFF	OFF	ON	-	-	-
ON	ON	OFF	OFF	-	ON	-	-
ON	ON	ON	OFF	-	-	ON	-
ON	ON	ON	ON	-	-	-	ON

Switch lamps chart

SWITCHES								LAMPS			
1st SET		2nd SET		3rd SET		4th SET		L_1	L_2	L_3	L_4
S_{11}	S_{12}	S_{21}	S_{22}	S_{31}	S_{32}	S_{41}	S_{42}				
ON	-	-	-	-	-	-	-	✓	✗	✗	✗
ON	OFF	-	-	-	-	-	-	✗	✗	✗	✗
ON	OFF	ON	-	-	-	-	-	✗	✓	✗	✗
ON	OFF	ON	OFF	-	-	-	-	✗	✗	✗	✗
ON	OFF	ON	OFF	ON	-	-	-	✗	✗	✓	✗
ON	OFF	ON	OFF	ON	OFF	-	-	✗	✗	✗	✗
ON	OFF	ON	OFF	ON	OFF	ON	-	✗	✗	✗	✓
ON	OFF	ON	OFF	ON	OFF	ON	OFF	✗	✗	✗	✗

MODE CHART FOR CORRIDOR WIRING

Godown lighting circuit

Let us consider a godown lighting circuit (Fig 4) having three lamps L_1, L_2, L_3 and L_4 which are to be controlled such that if one moves in a godown in either direction he can switch ON one light after the other in the forward direction while the lamp which was lighted earlier gets switched OFF. In an arrangement. S_1 is a one way switch, S_2, S_3 and S_4 are two-way switches.

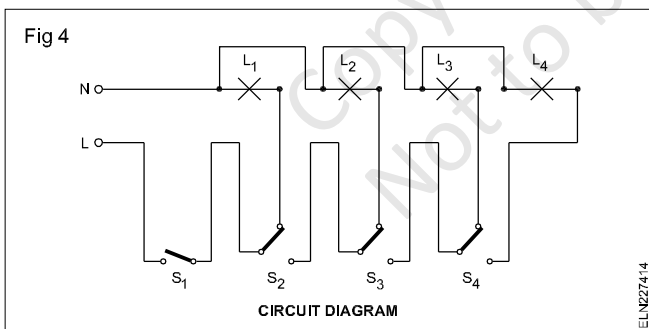

Bank / jail / hostel wiring (Fig 5)

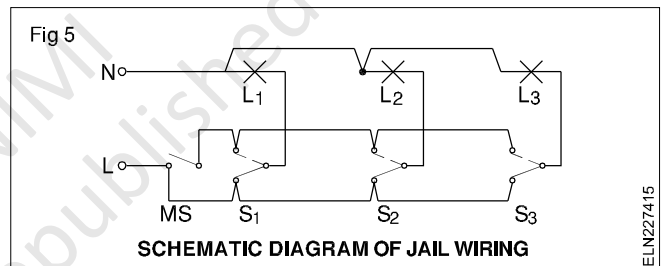

The master switch (MS) could be operated by the warden to make all the lights ON when they are all OFF.

Intermediate switch - specification and application in lighting circuit

Objectives: At the end of this lesson you shall be able to

- identify the features and specify an intermediate switch
- draw diagrams of a lighting circuit using intermediate switches.

An intermediate switch is a special type of switch having four terminals for connection. This switch is commonly used to control a lamp or load from three or more positions as encountered in the lighting of staircases, corridors, bedrooms.

Specifications of an intermediate switch

These switches are available in the market with two possible change over types of connections Figs 1a and 1b.

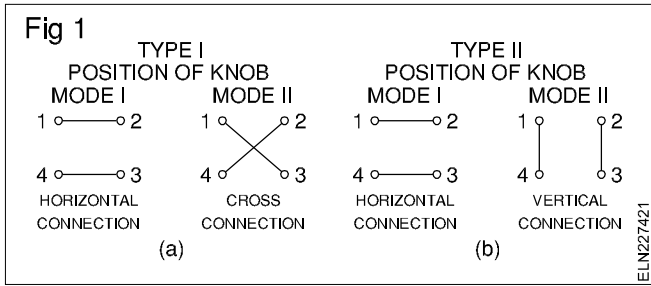

Accordingly the specification should contain the following information.

- Type of mounting
- Voltage rating

- Current rating
- Type of connection

Example

Flush mounting intermediate switch 250 V 6 A horizontal and cross connection.

Circuit connections

For controlling a lamp from three locations, one intermediate switch and 2 two-way switches could be used (Fig 2). Knob positions of the switches and the conditions of the lamp are also given along with Figure 2 for easy understanding.

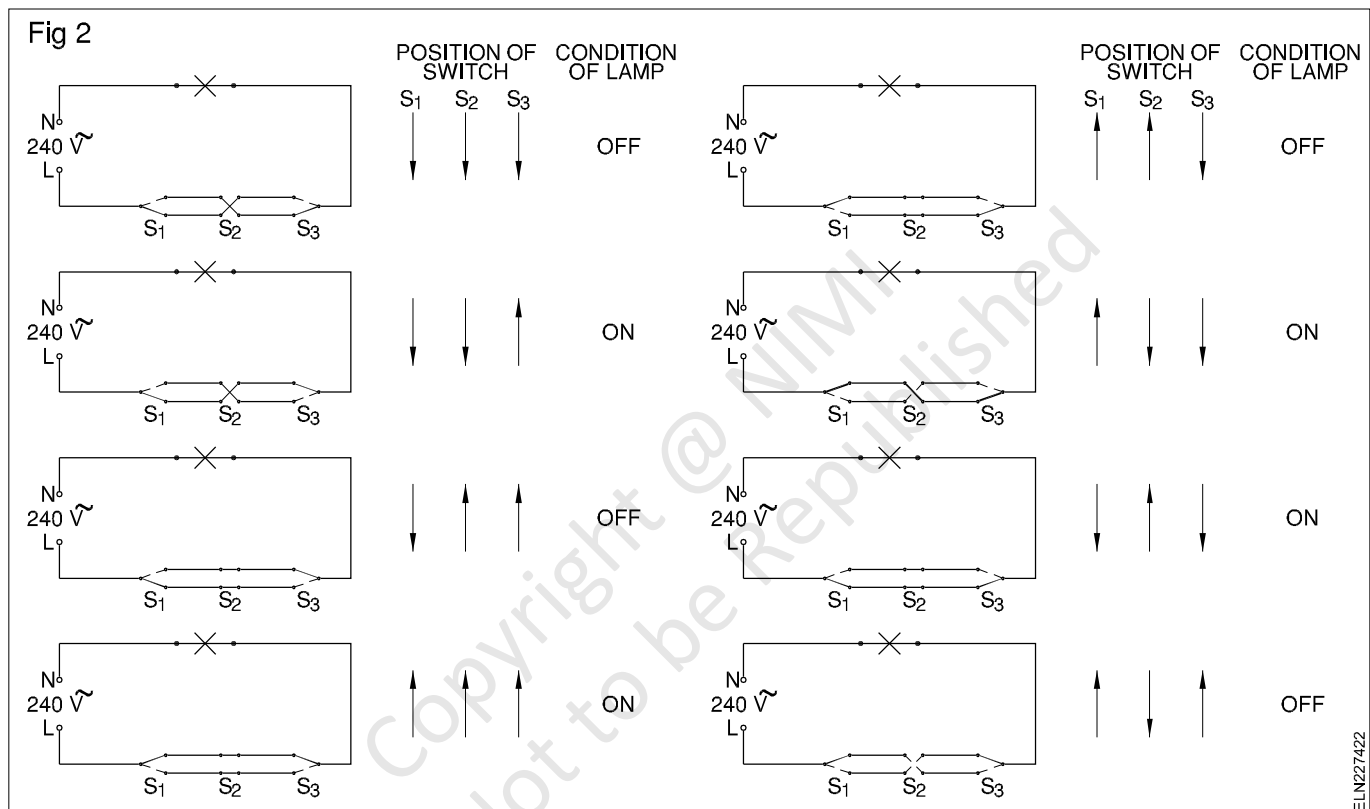

To control a lamp from three locations, three intermediate switches instead of a two two-way switches can also be used. (But, in practice, they are not used since it is very expensive).

Schematic diagrams (Figs 3 and 4) shows the method of controlling a lamp from three locations using three intermediate switches having horizontal and cross/ vertical connection respectively.

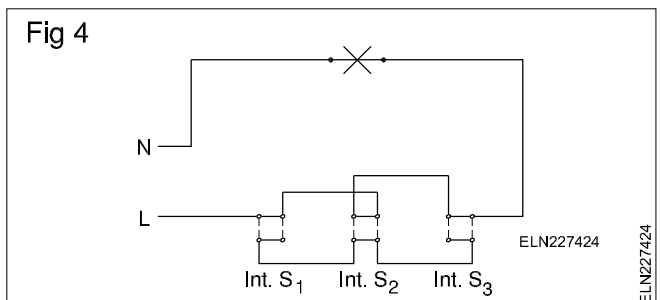
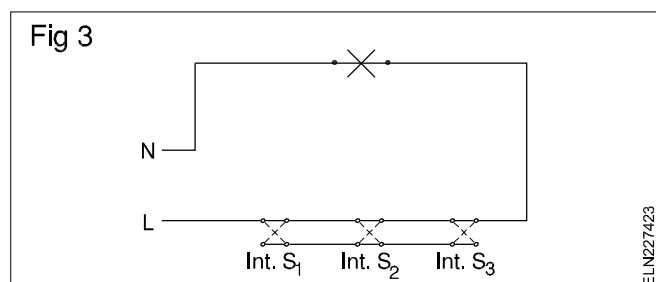

The schematic diagram (Fig 5) is for controlling one lamp from five locations using two two-way switches and three intermediate switches is given below.

In the schematic diagram (Fig 6) is for controlling one lamp from 3 positions with a master control as a security control switch. The lamp is controlled independently from three places by switches S_1 , S_2 and S_3 . When the master switch

'M' is 'ON' the lamp is permanently 'ON' and cannot be controlled by switches S_1 , S_2 and S_3 .

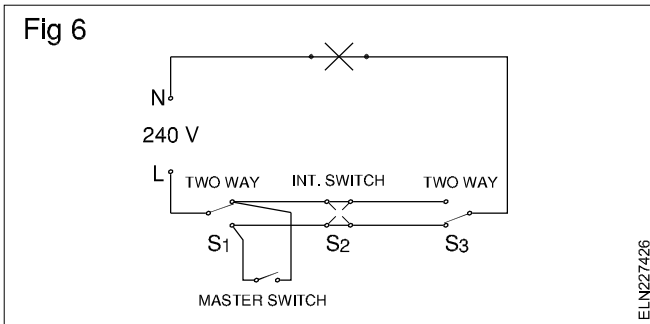
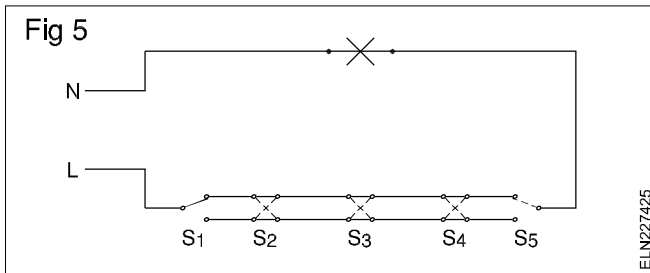

As intermediate switches are costly two numbers of two-way switches can be linked through a common bar and can be used as an intermediate switch (Fig 7). This circuit controls one lamp from 3 places.

